



UNIVERSITY OF RUHUNA

Faculty of Engineering

End-Semester 5 Examination in Engineering: August 2015

Module Number: CE 5204

Module Name: Structural Analysis III

[Three Hours]

[Answer all questions, each question carries 12 marks]

- Q1. a) List different types of yield lines? [1 Mark]
- b) Explain how you identify the yield lines, listed in Q1(a), in a reinforced concrete slab? [3 Marks]
- c) An orthotropic reinforced concrete slab is spanning over four beams at four edges as shown in Figure Q1. The yield moments per unit length of reinforcements, which are provided to resist sagging moment and hogging moment of the slab, are m and m' ($=2m$), respectively. Yield moments for each direction of the slab are shown in Figure Q1, and parameter μ can be assumed as 0.5. Yield moment for beam reinforcements is assumed to be $2mL$.
- Draw a possible yield line pattern at collapse.
 - Determine the exact distances between the supports and the intersecting points of the yield lines.
 - Determine the ultimate uniformly distributed load that can be carried by the slab.
- [8 Marks]

- Q2. a) What is the load resisting mechanism of a plate element? [2 Marks]
- b) A thin rectangular plate having a size of $a \times 2a$ is simply supported along all four edges. The plate carries a vertically downward load of intensity $q(x,y)$, which varies in the X and Y directions as given by

$$q(x,y) = q_0 \sin\left(\frac{\pi x}{a}\right) \sin\left(\frac{\pi y}{2a}\right)$$

where q_0 is the intensity of the load at the centre of the plate.

- Assume a trial solution for displacement and show that the trial solution satisfies the relevant displacement and stress boundary conditions.
- Determine deflection of the plate.
- Determine bending moments and shear forces.

Governing equation and the equations for bending moments and shear forces (with usual notations and sign convention) are given by

$$\frac{\partial^4 w}{\partial x^4} + 2 \frac{\partial^4 w}{\partial x^2 \partial y^2} + \frac{\partial^4 w}{\partial y^4} = \frac{q}{D} \quad M_x = -D \left(\frac{\partial^2 w}{\partial x^2} + \nu \frac{\partial^2 w}{\partial y^2} \right) \quad M_y = -D \left(\frac{\partial^2 w}{\partial y^2} + \nu \frac{\partial^2 w}{\partial x^2} \right)$$

$$Q_x = -D \left(\frac{\partial^3 w}{\partial x^3} + \frac{\partial^3 w}{\partial x \partial y^2} \right) \quad Q_y = -D \left(\frac{\partial^3 w}{\partial x^2 \partial y} + \frac{\partial^3 w}{\partial y^3} \right) \quad \text{where,}$$

$$D = \frac{Et^3}{12(1-\nu^2)}$$

[10 Marks]

- Q3. a) Explain briefly applications of thin circular plates? [2 Marks]
- b) A thin circular plate of radius of R , uniform thickness of t , Young's modulus of E and poisson ratio of ν , is assumed to be simply supported along the boundary. The plate is subjected to lateral downward central load of P_0 .
- i) Show that the shear force per unit length at distance, r , from the centre of the plate can be expressed as $Q = \frac{P_0}{2\pi r}$
- ii) Determine an expression for the deflection of the plate. Hence show that the central deflection can be expressed as $\frac{3P_0 R^2}{4\pi E t^3} (3 + \nu)(1 - \nu)$ [8 Marks]
- c) Determine the maximum value of P_0 when the plate deflection is limited to 1 mm. The thickness and the radius of the plate are 100 mm and 2 m, respectively. The E and ν of the plate material are 200 GPa and 0.3, respectively. Assume safety factor of failure is 2.

[2 Marks]

Governing equation and the equation for the radial moment of circular plate (with usual notations and sign convention) are given by

$$\frac{d}{dr} \left[\frac{1}{r} \frac{d}{dr} \left(r \frac{dw}{dr} \right) \right] = \frac{Q}{D} \quad M_r = -D \left(\frac{d^2 w}{dr^2} + \frac{\nu}{r} \frac{dw}{dr} \right) \quad M_\theta = -D \left(\frac{1}{r} \frac{dw}{dr} + \nu \frac{d^2 w}{dr^2} \right)$$

where

$$D = \frac{Et^3}{12(1-\nu^2)}$$

- Q4. a) "Structural materials are generally far more efficient in an extensional rather than in a flexural mode, making the arch and shell are preferable over the beam and plate"
Do you agree with this statement? Justify your answer providing reasons. [2 Marks]
- b) Show that the membrane stresses in a spherical shell (*with usual notations and sign convention*) are given by
- $$\frac{N_\phi}{r_1} + \frac{N_\theta}{r_2} = P_r \quad P_\theta r r_1 - r_1 N_\theta \cos \phi + \frac{\partial(r N_\phi)}{\partial \phi} = 0$$
- [4 Marks]
- c) A spherical dome having a radius of a subjected to a constant pressure of q , during

the construction process as shown in Figure Q4. The shell is simply supported along a parallel at a vertical angle of β .

Determine the stress resultants in the spherical dome, using the membrane theory derived in Q4(b)

[6 Marks]

Q5. A conical lantern shell, stiffened by the upper ring beam and the lower ring beam, is shown in Figure Q5. The shell structure is subjected to vertical line load of pR per unit length at the upper ring beam level and uniform dead load of p per unit surface area as shown in Figure Q5.

a) Determine the membrane stresses caused by above loading.

(Hint: Compute each loading case separately and then combine the results)

[8 Marks]

b) Compute the forces developed at the upper and lower horizontal ring beams.

[4 Marks]

The membrane stresses in a conical shell (with usual notations and sign convention) are given by

$$N_{\theta} = P_r S \tan \alpha$$

$$N_s = \frac{1}{S} \int (P_r S \tan \alpha - P_s S) ds$$

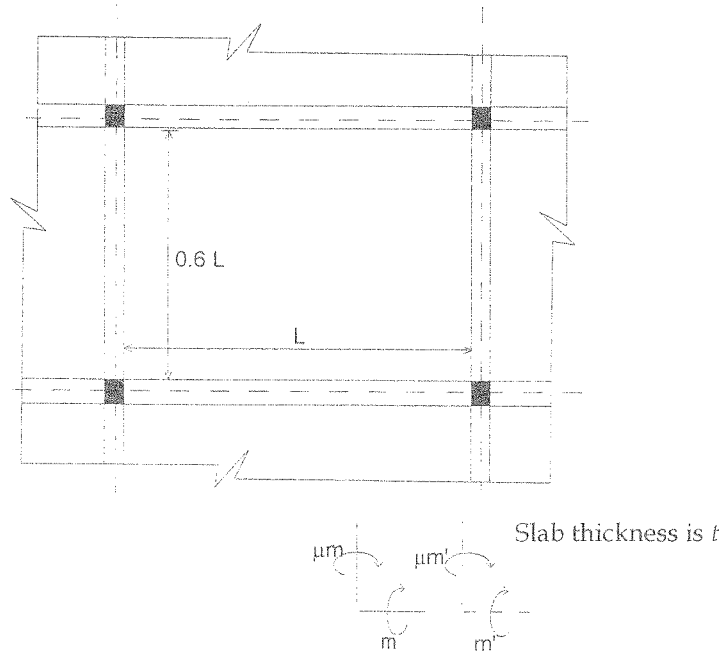

Figure Q1

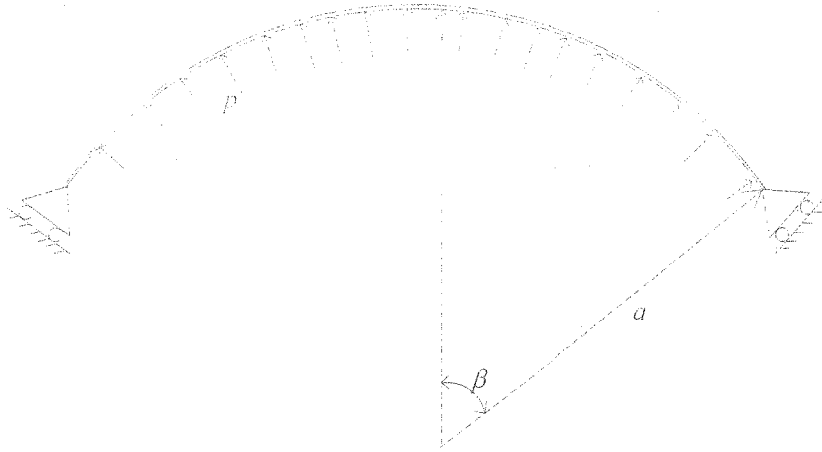

Figure Q4

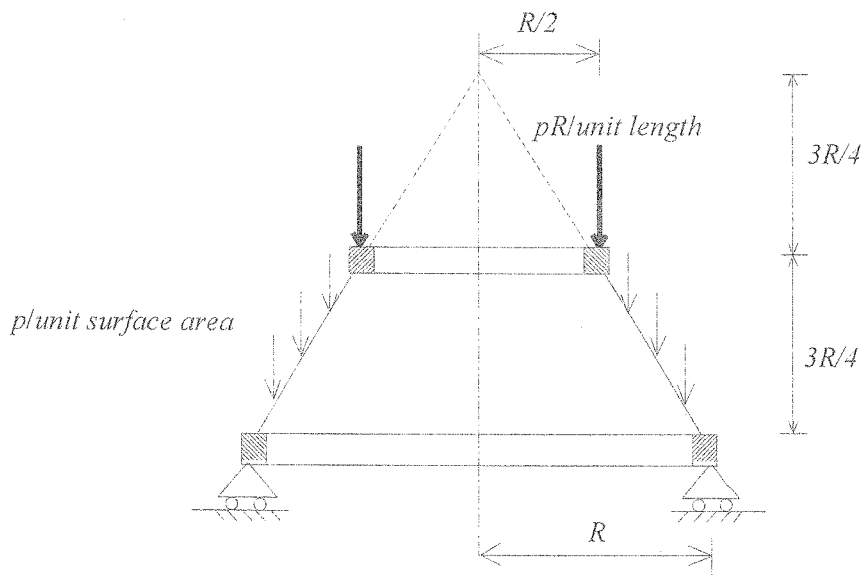

Figure Q5