

UNIVERSITY OF RUHUNA

BACHELOR OF SCIENCE GENERAL DEGREE – LEVEL I (SEMESTER I)  
EXAMINATION – DECEMBER - 2020

SUBJECT: Physics

TIME: Three (03) hours

COURSE UNIT: PHY 1114

Answer only 05 questions

Part II

---

(All symbols have their usual meaning)

1.

- a) A particle travelling with constant speed on a circular path of radius 7 m as shown in the figure, takes 20 s to complete one revolution.

Assume that the particle passes the origin at  $t = 0$ ,

- i. Find the particle displacement and the average velocity for the 5.0 s interval from the end of the 5<sup>th</sup> second to the end of the 10<sup>th</sup> second.

[06 marks]

- ii. What is the speed of the particle?

[02 marks]

- iii. Find the velocity of the particle at the 5<sup>th</sup> and the 10<sup>th</sup> seconds.

[04 marks]

- iv. Find the velocity of the particle at the 5<sup>th</sup> and the 10<sup>th</sup> seconds.

[04 marks]

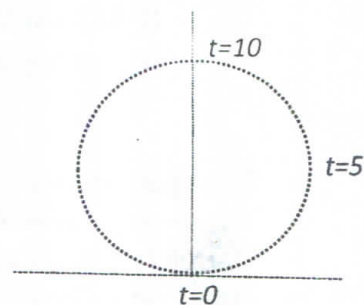

- b) A block of mass  $m$  is pulled upward by a string of tension  $T$  along a rough inclined plane. The inclination of the plane is  $\theta$  and the kinetic frictional force between the plane and the object is  $f_k$ .

- i. Indicate all forces acting on the block and distinguish conservative and non-conservative forces among them.

[04 marks]

- ii. If the block is started at rest at the bottom of the inclined plane initially, using **only the work-energy relation** obtain an expression for the velocity of the block after it is pulled a distance  $s$  along the inclined plane.

[05 marks]

2. A beaker of mass 1 kg containing 2 kg of water rests on a scale P as shown in the figure. A metal block of density  $2 \times 10^3 \text{ kg/m}^3$  is suspended on a spring scale (scale Q) which reads 2 kg. Then the block is submerged in water (density of water  $1 \times 10^3 \text{ kg/m}^3$ , and  $g = 10 \text{ ms}^{-2}$ ).

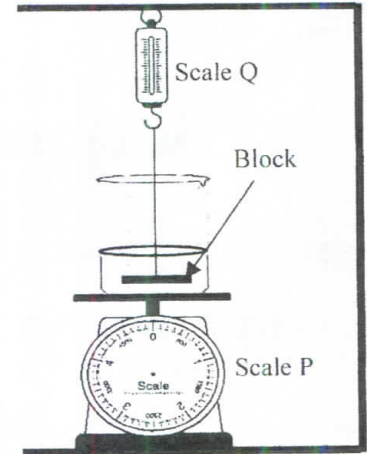

- i. Calculate the buoyant force acting on the block. [03 marks]
- ii. Find the new reading of the scale P, after submerging the block. [05 marks]
- iii. Find the new reading of the scale Q, after submerging the block. [03 marks]
- iv. If the system is inside an elevator which is accelerated upward with 3 times the gravitational acceleration, find the readings of both scales. [08 marks]
- v. If the elevator is accelerated upward with 3 times the gravitational acceleration, would the reading of scale Q be zero? Verify your answer with necessary calculations. [06 marks]

3. The figure shows a freely rotatable wheel in which the axis of rotation (spin axis) is also free to take any orientation by itself. One end of the axle of the wheel is grasped by a chain and the other end is initially held as shown in the figure and then released. The mass of the wheel is  $M$  and assume that all mass is distributed on the outer ring. Mass of the axle is negligible compared to the wheel. The distance from the grasping point to the center of the axle is  $r$ .

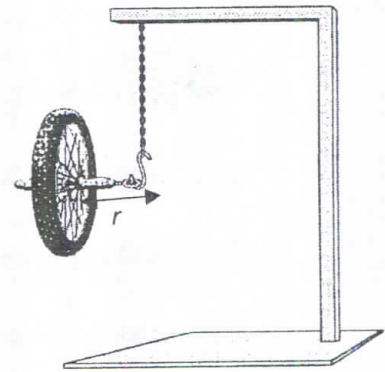

- i. For the initial position of the wheel, write down an expression for the torque on the wheel using the given information. Indicate the direction of the torque. [02 marks]
- ii. If the wheel is not spinning, which type of motion is undergone by the wheel? Giving expressions, briefly explain your answer. [02 marks]
- iii. If the wheel is set to spin around the horizontal axle in the counter clockwise direction as seen from the outside with angular frequency  $\omega$  and released, which type of motion is expected? Explain your answer, briefly, with a suitable expression. [08 marks]
- iv. Show that the precession angular frequency of the wheel,  $\Omega = \frac{Mgr}{I\omega}$ ; where  $I$  is the moment of inertia of the wheel around its axle and  $g$  is the acceleration due to gravity. [06 marks]

Continue to next page....

- v. A symmetric top of mass  $M$  is spinning with the angular frequency  $\omega$ , as shown in the figure. Obtain an expression for the precession angular frequency of the spinning top and compare it with the result in part (iv).  $I$  is the moment of inertia about the symmetric rotating axis of the top and  $r$  is the distance to the center of gravity of the top along the axis as shown in the figure.

[07 marks]

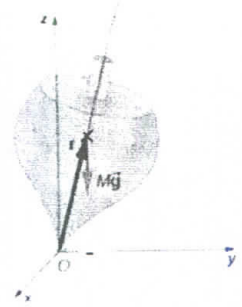

4.

- a) A particle of mass  $m$  moving with velocity  $u$  collides with another mass  $M$ , which is at rest.

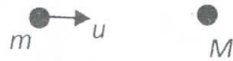

- Find the velocity of the Center of Mass (C.O.M) frame of the two particles.
- Find the velocity of each particle in the C.O.M frame before the collision.
- Write down the velocity of each particle after the collision in the C.O.M frame.

[05 marks]

- b) A mass **A** of 30 kg and speed  $100\text{ms}^{-1}$  moving in the +X direction makes an elastic and inclined collision with a mass **B** of 70 kg at rest. The mass B moves in a direction  $60^\circ$  to the +X direction in the center of mass frame of the system after the collision.

- Calculate the velocity of the C.O.M of the system. [02 marks]
- Calculate the velocity of each mass in C.O.M frame before the collision. [04 marks]
- Calculate the velocity of each mass in the C.O.M frame after the collision. [04 marks]
- Calculate the velocity of each mass in the laboratory frame after the collision. [10 marks]

5.

- a) Show that the moment of inertia of a thin uniform disk of radius  $R$  and mass  $M$ , around an axis passing through its center normal to the plane of the disk is  $\frac{1}{2}MR^2$ .

[06 marks]

- b) A thin uniform solid disk of mass  $M$  and radius  $R$  is fixed to a vertical shaft as shown in the figure below. The shaft is attached to a coil spring which exerts a linear restoring torque of magnitude  $C\theta$ , where  $\theta$  is the angle measured from the static equilibrium position and  $C$  is a constant. Neglect the mass of the shaft and the spring. Assume the bearings in the shaft to be frictionless.



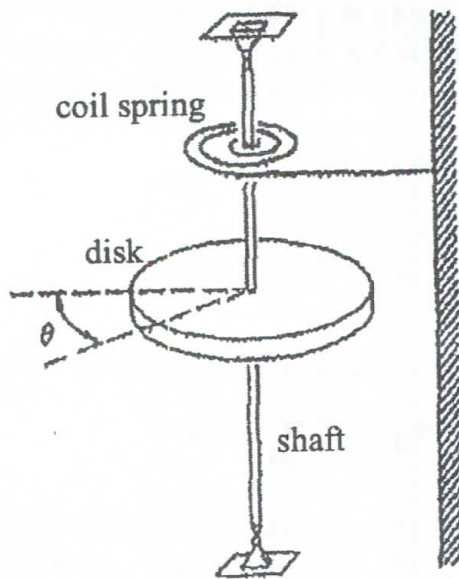

- (i) Show that the disk can undergo rotational simple harmonic motion. [05 marks]
- (ii) Find the angular frequency ( $\omega$ ) and the time period ( $T$ ) of the motion. [04 marks]
- c) Suppose that the disk is rotating according to  $\theta = \theta_0 \sin(\omega t + \phi)$ , where  $\omega$  is the angular frequency found in part (b) (ii). When the disk is passing its equilibrium position, a ring of sticky clay of mass  $M$  and radius  $R$  is dropped concentrically on the disk
- (i) Find the maximum angular velocity of the disk when it is passing the equilibrium position just before it gets the sticky clay ring on it. [02 marks]
- (ii) Find the new moment of inertia ( $I_n$ ) of the system with the sticky clay ring on it. [03 marks]
- (iii) Find the new amplitude of the motion in terms of  $\theta_0$  [05 marks]

6.

- a) Consider the two waves,  $y_1 = a \sin(kx - \omega t)$  and  $y_2 = a \sin(kx - \omega t + \phi)$  that travel in the positive  $x$ -direction.

- (i) Derive an expression for the resultant wave and write down its amplitude, angular frequency, phase constant and its travelling direction. [08 marks]

$$\text{note: } \sin(c) + \sin(d) = 2 \sin\left(\frac{c+d}{2}\right) \cos\left(\frac{c-d}{2}\right)$$

- (ii) Discuss how the amplitude of the resultant wave depends on the phase difference ( $\phi$ ), between the two waves  $y_1$  and  $y_2$ . [04 marks]

(iii) Two speakers ( $S_1$  and  $S_2$ ) driven by the same sound source, emit sound waves of 5 kHz in air as shown in the figure below. Calculate the distance  $x$ , where the first order constructive interference takes place at point P. Assume that the speed of sound in air is  $343 \text{ m s}^{-1}$ .

[04 marks]

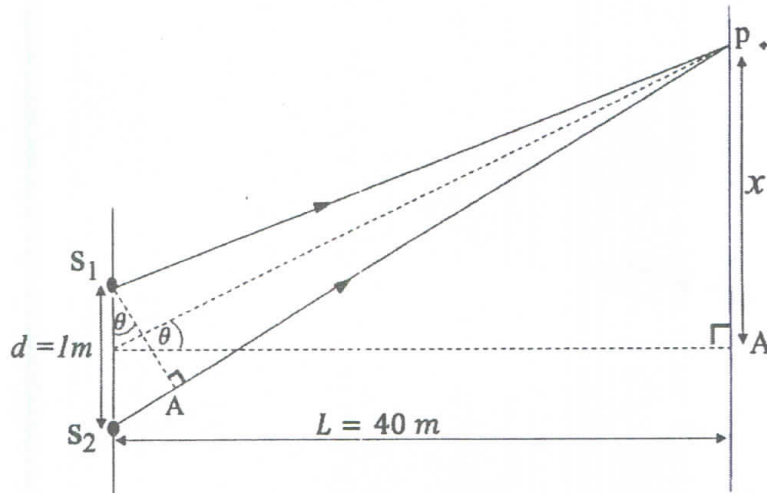

b) Two strings of linear mass densities  $\mu_1$  and  $\mu_2 (= 4\mu_1)$  are joined together and stretched with the same tension  $T$ . A transverse wave pulse with amplitude  $A$  is created in the string with lower density and it is moving towards the boundary of the two strings.

(i) Calculate the amplitudes of the reflected and transmitted waves.

[06 marks]

(ii) Draw the shapes of the incident wave pulse and the corresponding reflected and transmitted wave pulses.

[03 marks]