



UNIVERSITY OF RUHUNA

Faculty of Engineering

End-Semester 5 Examination in Engineering: March 2022

Module Number: CE5201 (N/C) Module Name: Design of Steel Structures

[Time: Three Hours]

[Answer all questions, each question carries equal marks]

- Q1. A lattice girder made in grade S275 steel supports a reinforced concrete floor as shown in Fig.Q1. The applied load on the floor is due to permanent and variable distributed loads which transmitted to the truss as concentrated loads applied to the nodal points. Thus, the concentrated loads shown in Fig.Q1(b) were calculated based on the influence areas of each node considering the distance between the lattice girders. In the same figure, the internal forces in the members are also given.
- Identify the design member forces in the bottom chord, the top chord, and the diagonal members. [3 Marks]
 - If the 152 x 152 x 23 UC sections are used as the top and bottom chords, check the adequacy of this section for both tension and compression actions. [8 Marks]
 - If the diagonal members are back-to-back **channel** sections of size 100 x 50 x 10 C, check the adequacy of this section for diagonal members. [4 Marks]
- Q2. The beam with a length $L = 6.0$ m is laterally restrained at the supports (i.e., A and D) and the load application points (i.e., B and C) as shown in Fig.Q2. The characteristic loads of permanent $G_k = 20$ kN and variable $Q_k = 30$ kN are transferred to the beam ABCD at points B and C as two concentrated loads. An initial section of size 254 x 146 x 37 UB is selected in grade S235 steel for the design verification.
- Estimate concentrated design load at points B and C at the ULS condition. [1 Mark]
 - If the beam-column connection is made by using a web cleat, draw the bending moment and shear force diagrams and hence determine the design bending moment and shear force values to verify cross section resistance. [3 Marks]
 - Check whether the proposed beam section is sufficient to withstand design shear force, bending moment, and combined effect of those. [4 Marks]
 - Check whether the given restraining conditions are sufficient to resist the lateral torsional buckling of segment BC. M_{cr} for segment BC is 206 kNm. [4 Marks]
 - If the maximum vertical deflection is at the mid-span is given by $\delta_{max} = \frac{11PL^3}{384EI}$, calculate the serviceability limit state of deflection for the characteristic combination of load and verify adequacy by considering $\delta_{max} \leq L/300$. Assume $E=210$ GPa. [3 Marks]

Q3. A steel column AB that supports a steel cantilever beam BC, is shown in Fig.Q3(a). The column is fixed at the base A while the top B is free to rotate but restrained from horizontal displacements in both directions. The column has a rectangular hollow section of RHS 200 x 150 x 8 mm in grade S355 steel ($E = 210 \text{ GPa}$ and $G = 81 \text{ GPa}$). Assume that the indicated loading is already factored for ULS. For the given design loading, the internal force and moment diagrams for column AB are shown in Fig. Q3(b).

a) For the combined effect of bending and axial compression, verify the adequacy of cross section resistance capacity in column AB according to EC3 1-1. [6 Marks]

b) Using Annex B method given in EC3-1-1, check the buckling resistance capacity of column AB for combined bending and axial loading. [9 Marks]

Q4. Fig. Q4 (a) to Fig.Q4(c) show a beam-to-beam connection in a steel structure. The secondary beam of 254 x 146 x 37 UB transfers a design shear force $V_{Ed} = 60 \text{ kN}$ to the main beam of 356 x 171 x 57 UB. Grade of steel is S235 and M16 bolts of class 4.6 are used. Assumed that 6 no of M16 bolts transfer only the design shear force V_{Ed} from the secondary beam to the main beam without any simultaneous development of bending moment. In contrast, 3 no of M16 bolts connecting L angles to the web of secondary beam transfer both shear and bending and therefore horizontal shear also developed as indicated in Fig. Q4 (b). [Hint: for moment balance, $V_{Ed} \times 45 = H_{Ed} \times 100$]

a) Check whether the given detailing satisfy minimum and maximum end, edge, and spacing distances of the connections. [3 Marks]

b) Estimate the design shear force in 3 no of M16 bolt group and 6 no of M16 bolt group separately. [4 Marks]

c) Check the adequacy of above two bolt groups. [8 Marks]

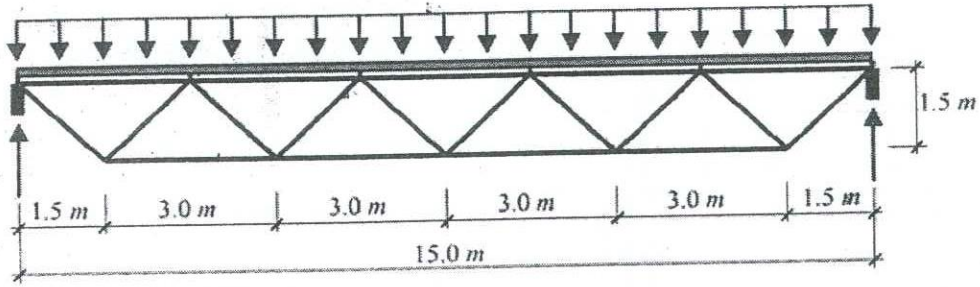

Fig. Q1(a)

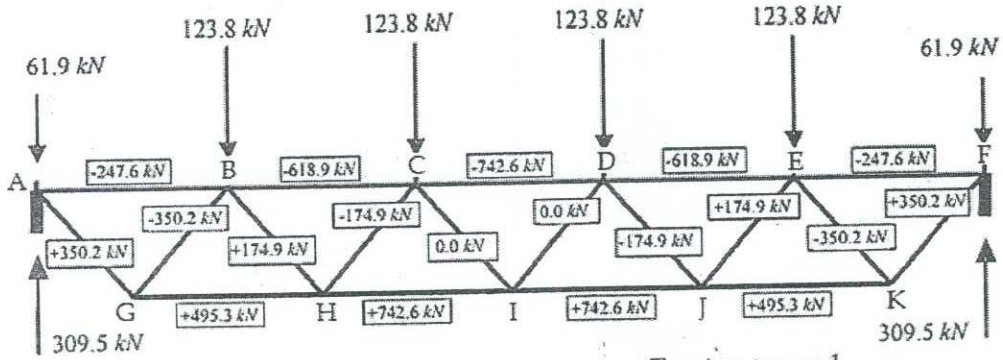

Fig. Q1(b)

Tension +ve and
compression -ve

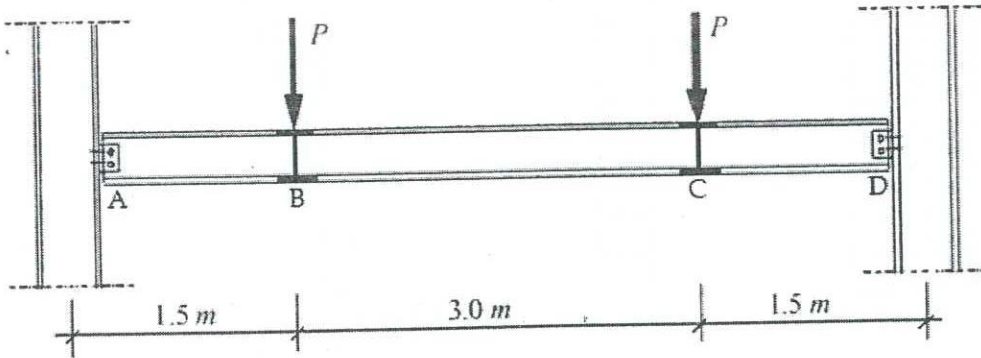

Fig. Q2

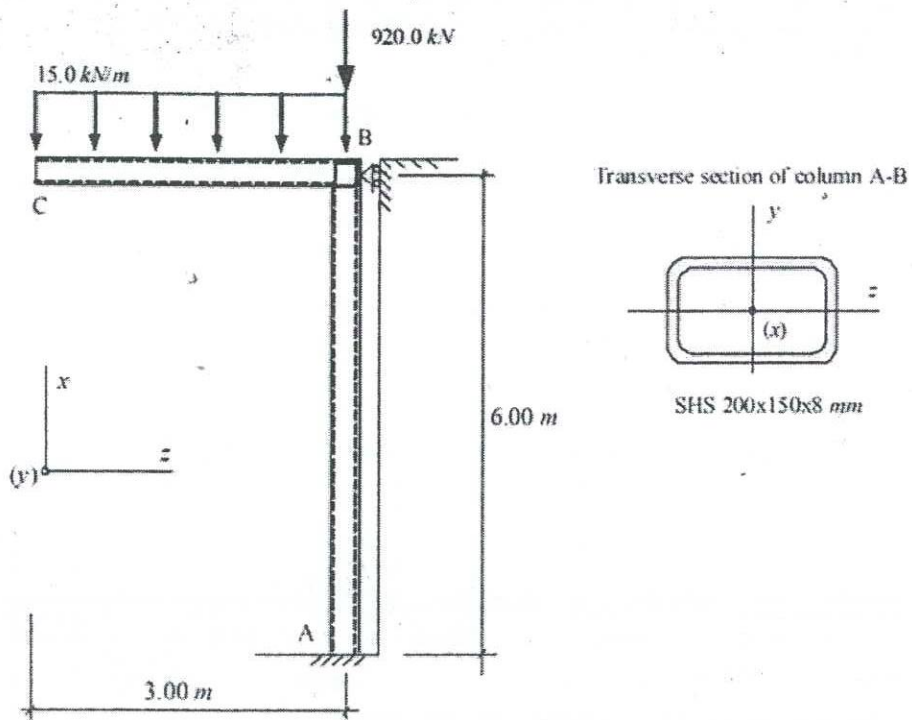

Fig.Q3(a)

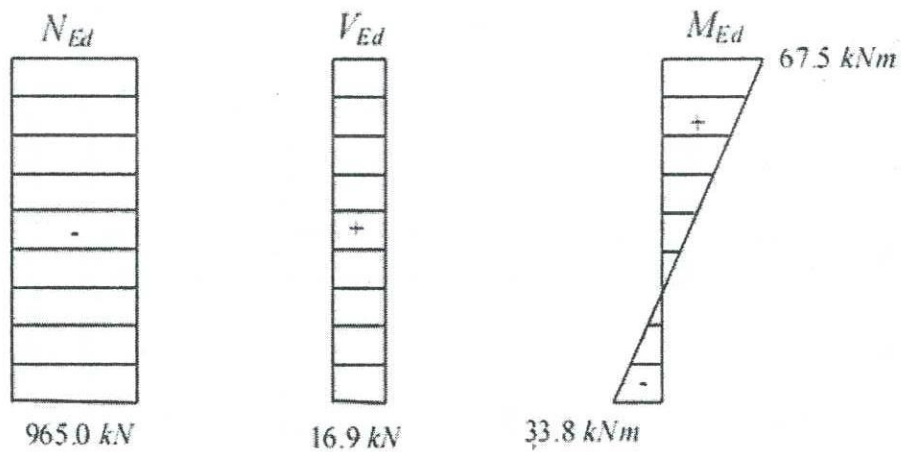

Fig. Q3(b)

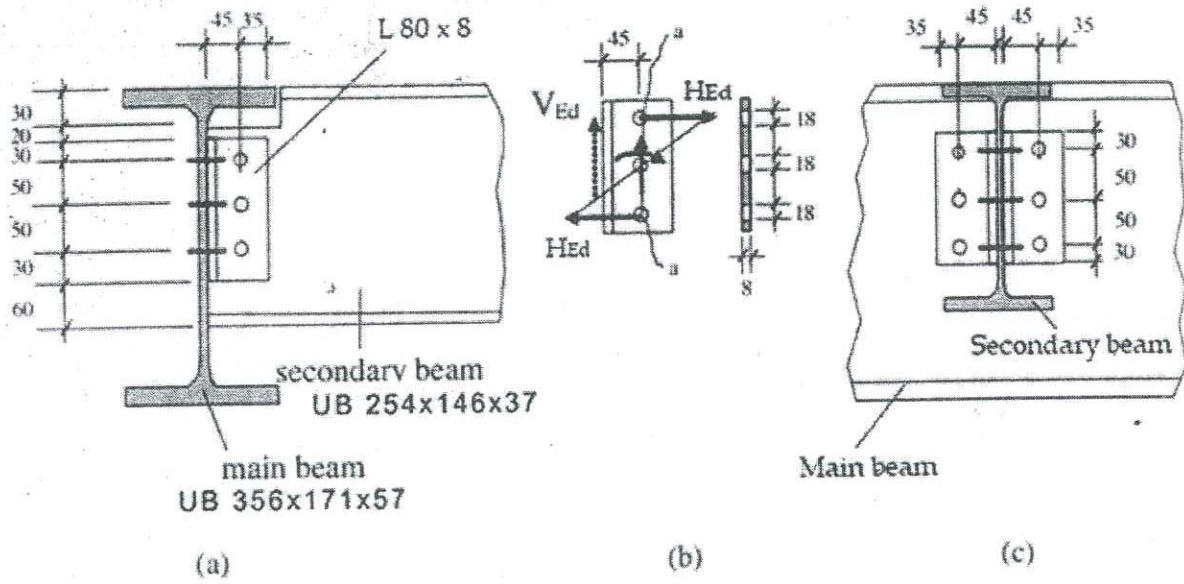
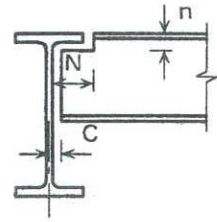
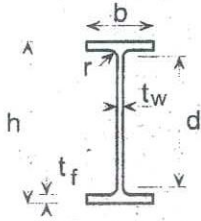

Fig. 04

BS EN 1993-1-1:2005
BS 4-1:2005

UNIVERSAL BEAMS

Advance UKB



Dimensions

Section Designation	Mass per Metre kg/m	Depth of Section h mm	Width of Section b mm	Thickness		Root Radius r mm	Depth between Fillets d mm	Ratios for Local Buckling		Dimensions for Detailing			Surface Area	
				Web t _w mm	Flange t _f mm			Flange c _f / t _f	Web c _w / t _w	End Clearance C mm	Notch		Per Metre m ²	Per Tonne m ²
											N mm	n mm		
533x210x138 +	138.3	549.1	213.9	14.7	23.6	12.7	476.5	3.68	32.4	9	110	38	1.90	13.7
533x210x122	122.0	544.5	211.9	12.7	21.3	12.7	476.5	4.08	37.5	8	110	34	1.89	15.5
533x210x109	109.0	539.5	210.8	11.6	18.8	12.7	476.5	4.62	41.1	8	110	32	1.88	17.2
533x210x101	101.0	536.7	210.0	10.8	17.4	12.7	476.5	4.99	44.1	7	110	32	1.87	18.5
533x210x92	92.1	533.1	209.3	10.1	15.6	12.7	476.5	5.57	47.2	7	110	30	1.86	20.2
533x210x82	82.2	528.3	208.8	9.6	13.2	12.7	476.5	6.58	49.6	7	110	26	1.85	22.5
533x165x85 +	84.8	534.9	166.5	10.3	16.5	12.7	476.5	3.96	46.3	7	90	30	1.69	19.9
533x165x75 +	74.7	529.1	165.9	9.7	13.6	12.7	476.5	4.81	49.1	7	90	28	1.68	22.5
533x165x66 +	65.7	524.7	165.1	8.9	11.4	12.7	476.5	5.74	53.5	6	90	26	1.67	25.4
457x191x161 +	161.4	492.0	199.4	18.0	32.0	10.2	407.6	2.52	22.6	11	102	44	1.73	10.7
457x191x133 +	133.3	480.6	196.7	15.3	26.3	10.2	407.6	3.06	26.6	10	102	38	1.70	12.8
457x191x106 +	105.8	469.2	194.0	12.6	20.6	10.2	407.6	3.91	32.3	8	102	32	1.67	15.8
457x191x98	98.3	467.2	192.8	11.4	19.6	10.2	407.6	4.11	35.8	8	102	30	1.67	17.0
457x191x89	89.3	463.4	191.9	10.5	17.7	10.2	407.6	4.55	38.8	7	102	28	1.66	18.6
457x191x82	82.0	460.0	191.3	9.9	16.0	10.2	407.6	5.03	41.2	7	102	28	1.65	20.1
457x191x74	74.3	457.0	190.4	9.0	14.5	10.2	407.6	5.55	45.3	7	102	26	1.64	22.1
457x191x67	67.1	453.4	189.9	8.5	12.7	10.2	407.6	6.34	48.0	6	102	24	1.63	24.3
457x152x82	82.1	465.8	155.3	10.5	18.9	10.2	407.6	3.29	38.8	7	84	30	1.51	18.4
457x152x74	74.2	462.0	154.4	9.6	17.0	10.2	407.6	3.66	42.5	7	84	28	1.50	20.2
457x152x67	67.2	458.0	153.8	9.0	15.0	10.2	407.6	4.15	45.3	7	84	26	1.50	22.3
457x152x60	59.8	454.6	152.9	8.1	13.3	10.2	407.6	4.68	50.3	6	84	24	1.49	24.9
457x152x52	52.3	449.8	152.4	7.6	10.9	10.2	407.6	5.71	53.6	6	84	22	1.48	28.3
406x178x85 +	85.3	417.2	181.9	10.9	18.2	10.2	360.4	4.14	33.1	7	96	30	1.52	17.8
406x178x74	74.2	412.8	179.5	9.5	16.0	10.2	360.4	4.68	37.9	7	96	28	1.51	20.4
406x178x67	67.1	409.4	178.8	8.8	14.3	10.2	360.4	5.23	41.0	6	96	26	1.50	22.3
406x178x60	60.1	406.4	177.9	7.9	12.8	10.2	360.4	5.84	45.6	6	96	24	1.49	24.8
406x178x54	54.1	402.6	177.7	7.7	10.9	10.2	360.4	6.86	46.8	6	96	22	1.48	27.3
406x140x53 +	53.3	406.6	143.3	7.9	12.9	10.2	360.4	4.46	45.6	6	78	24	1.35	25.3
406x140x46	46.0	403.2	142.2	6.8	11.2	10.2	360.4	5.13	53.0	5	78	22	1.34	29.1
406x140x39	39.0	398.0	141.8	6.4	8.6	10.2	360.4	6.69	56.3	5	78	20	1.33	34.1
356x171x67	67.1	363.4	173.2	9.1	15.7	10.2	311.6	4.58	34.2	7	94	26	1.38	20.6
356x171x57	57.0	358.0	172.2	8.1	13.0	10.2	311.6	5.53	38.5	6	94	24	1.37	24.1
356x171x51	51.0	355.0	171.5	7.4	11.5	10.2	311.6	6.25	42.1	6	94	22	1.36	26.7
356x171x45	45.0	351.4	171.1	7.0	9.7	10.2	311.6	7.41	44.5	6	94	20	1.36	30.2
356x127x39	39.1	353.4	126.0	6.6	10.7	10.2	311.6	4.63	47.2	5	70	22	1.18	30.2
356x127x33	33.1	349.0	125.4	6.0	8.5	10.2	311.6	5.82	51.9	5	70	20	1.17	35.4
305x165x54	54.0	310.4	166.9	7.9	13.7	8.9	265.2	5.15	33.6	6	90	24	1.26	23.3
305x165x46	46.1	306.6	165.7	6.7	11.8	8.9	265.2	5.98	39.6	5	90	22	1.25	27.1
305x165x40	40.3	303.4	165.0	6.0	10.2	8.9	265.2	6.92	44.2	5	90	20	1.24	30.8

Advance and UKB are trademarks of Corus. A fuller description of the relationship between Universal Beams (UB) and the Advance range of sections manufactured by Corus is given in section 12.

+ These sections are in addition to the range of BS 4 sections.

FOR EXPLANATION OF TABLES SEE NOTE 2

BS EN 1993-1-1:2005
BS 4-1:2005

UNIVERSAL BEAMS

Advance UKB

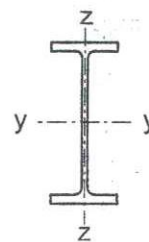

Properties

Section Designation	Second Moment of Area		Radius of Gyration		Elastic Modulus		Plastic Modulus		Buckling Parameter U	Torsional Index X	Warping Constant I_w dm ⁶	Torsional Constant I_T cm ⁴	Area of Section A cm ²
	Axis y-y	Axis z-z	Axis y-y	Axis z-z	Axis y-y	Axis z-z	Axis y-y	Axis z-z					
	cm ⁴	cm ⁴	cm	cm	cm ³	cm ³	cm ³	cm ³					
533x210x138 +	86100	3860	22.1	4.68	3140	361	3610	568	0.874	24.9	2.67	250	176
533x210x122	76000	3390	22.1	4.67	2790	320	3200	500	0.878	27.6	2.32	178	155
533x210x109	66800	2940	21.9	4.60	2480	279	2830	436	0.875	30.9	1.99	126	139
533x210x101	61500	2690	21.9	4.57	2290	256	2610	399	0.874	33.1	1.81	101	129
533x210x92	55200	2390	21.7	4.51	2070	228	2360	355	0.873	36.4	1.60	75.7	117
533x210x82	47500	2010	21.3	4.38	1800	192	2060	300	0.863	41.6	1.33	51.5	105
533x165x85 +	48500	1270	21.2	3.44	1820	153	2100	243	0.861	35.5	0.857	73.8	108
533x165x75 +	41100	1040	20.8	3.30	1550	125	1810	200	0.853	41.1	0.691	47.9	95.2
533x165x66 +	35000	859	20.5	3.20	1340	104	1560	166	0.847	47.0	0.566	32.0	83.7
457x191x161 +	79800	4250	19.7	4.55	3240	426	3780	672	0.881	16.5	2.25	515	206
457x191x133 +	63800	3350	19.4	4.44	2660	341	3070	535	0.879	19.6	1.73	292	170
457x191x106 +	48900	2510	19.0	4.32	2080	259	2390	405	0.876	24.4	1.27	146	135
457x191x98	45700	2350	19.1	4.33	1960	243	2230	379	0.881	25.8	1.18	121	125
457x191x89	41000	2090	19.0	4.29	1770	218	2010	338	0.878	28.3	1.04	90.7	114
457x191x82	37100	1870	18.8	4.23	1610	196	1830	304	0.879	30.8	0.922	69.2	104
457x191x74	33300	1670	18.8	4.20	1460	176	1650	272	0.877	33.8	0.818	51.8	94.6
457x191x67	29400	1450	18.5	4.12	1300	153	1470	237	0.873	37.8	0.705	37.1	85.5
457x152x82	36600	1180	18.7	3.37	1570	153	1810	240	0.872	27.4	0.591	89.2	105
457x152x74	32700	1050	18.6	3.33	1410	136	1630	213	0.872	30.1	0.518	65.9	94.5
457x152x67	28900	913	18.4	3.27	1260	119	1450	187	0.868	33.6	0.448	47.7	85.6
457x152x60	25500	795	18.3	3.23	1120	104	1290	163	0.868	37.5	0.387	33.8	76.2
457x152x52	21400	645	17.9	3.11	950	84.6	1100	133	0.859	43.8	0.311	21.4	66.6
406x178x85 +	31700	1830	17.1	4.11	1520	201	1730	313	0.880	24.4	0.728	93.0	109
406x178x74	27300	1550	17.0	4.04	1320	172	1500	267	0.882	27.5	0.608	62.8	94.5
406x178x67	24300	1360	16.9	3.99	1190	153	1350	237	0.880	30.4	0.533	46.1	85.5
406x178x60	21600	1200	16.8	3.97	1060	135	1200	209	0.880	33.7	0.466	33.3	76.5
406x178x54	18700	1020	16.5	3.85	930	115	1050	178	0.871	38.3	0.392	23.1	69.0
406x140x53 +	18300	635	16.4	3.06	899	88.6	1030	139	0.870	34.1	0.246	29.0	67.9
406x140x46	15700	538	16.4	3.03	778	75.7	888	118	0.871	39.0	0.207	19.0	58.6
406x140x39	12500	410	15.9	2.87	629	57.8	724	90.8	0.858	47.4	0.155	10.7	49.7
356x171x67	19500	1360	15.1	3.99	1070	157	1210	243	0.886	24.4	0.412	55.7	85.5
356x171x57	16000	1110	14.9	3.91	896	129	1010	199	0.882	28.8	0.330	33.4	72.6
356x171x51	14100	968	14.8	3.86	796	113	896	174	0.881	32.1	0.286	23.8	64.9
356x171x45	12100	811	14.5	3.76	687	94.8	775	147	0.874	36.8	0.237	15.8	57.3
356x127x39	10200	358	14.3	2.68	576	56.8	659	89.0	0.871	35.2	0.105	15.1	49.8
356x127x33	8250	280	14.0	2.58	473	44.7	543	70.2	0.863	42.1	0.081	8.79	42.1
305x165x54	11700	1060	13.0	3.93	754	127	846	196	0.889	23.6	0.234	34.8	68.8
305x165x46	9900	896	13.0	3.90	646	108	720	166	0.890	27.1	0.195	22.2	58.7
305x165x40	8500	764	12.9	3.86	560	92.6	623	142	0.889	31.0	0.164	14.7	51.3

Advance and UKB are trademarks of Corus. A fuller description of the relationship between Universal Beams (UB) and the Advance range of sections manufactured by Corus is given in section 12.

+ These sections are in addition to the range of BS 4 sections.

FOR EXPLANATION OF TABLES SEE NOTE 3

BS EN 1993-1-1:2005
BS 4-1:2005

UNIVERSAL BEAMS

Advance UKB

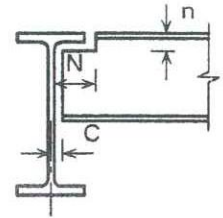
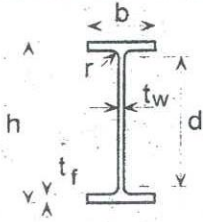

Dimensions

Section Designation	Mass per Metre kg/m	Depth of Section h mm	Width of Section b mm	Thickness		Root Radius r mm	Depth between Fillets d mm	Ratios for Local Buckling		Dimensions for Detailing			Surface Area	
				Web tw mm	Flange tf mm			Flange cf / tf	Web cw / tw	End Clearance C mm	Notch		Per Metre m ²	Per Tonne m ²
											N mm	n mm		
305x127x48	48.1	311.0	125.3	9.0	14.0	8.9	265.2	3.52	29.5	7	70	24	1.09	22.7
305x127x42	41.9	307.2	124.3	8.0	12.1	8.9	265.2	4.07	33.2	6	70	22	1.08	25.8
305x127x37	37.0	304.4	123.4	7.1	10.7	8.9	265.2	4.60	37.4	6	70	20	1.07	23.9
305x102x33	32.8	312.7	102.4	6.6	10.8	7.6	275.9	3.73	41.8	5	58	20	1.01	30.8
305x102x28	28.2	308.7	101.8	6.0	8.8	7.6	275.9	4.58	46.0	5	58	18	1.00	35.5
305x102x25	24.8	305.1	101.6	5.8	7.0	7.6	275.9	5.76	47.6	5	58	16	0.992	40.0
254x146x43	43.0	259.6	147.3	7.2	12.7	7.6	219.0	4.92	30.4	6	82	22	1.08	25.1
254x146x37	37.0	256.0	146.4	6.3	10.9	7.6	219.0	5.73	34.8	5	82	20	1.07	23.9
254x146x31	31.1	251.4	146.1	6.0	8.6	7.6	219.0	7.26	36.5	5	82	18	1.06	34.0
254x102x28	28.3	260.4	102.2	6.3	10.0	7.6	225.2	4.04	35.7	5	58	18	0.904	31.9
254x102x25	25.2	257.2	101.9	6.0	8.4	7.6	225.2	4.80	37.5	5	58	16	0.897	35.7
254x102x22	22.0	254.0	101.6	5.7	6.8	7.6	225.2	5.93	39.5	5	58	16	0.890	40.5
203x133x30	30.0	206.8	133.9	6.4	9.6	7.6	172.4	5.85	26.9	5	74	18	0.923	30.8
203x133x25	25.1	203.2	133.2	5.7	7.8	7.6	172.4	7.20	30.2	5	74	16	0.915	36.5
203x102x23	23.1	203.2	101.8	5.4	9.3	7.6	169.4	4.37	31.4	5	60	18	0.790	34.2
178x102x19	19.0	177.8	101.2	4.8	7.9	7.6	146.8	5.14	30.6	4	60	16	0.738	33.7
152x89x16	16.0	152.4	88.7	4.5	7.7	7.6	121.8	4.48	27.1	4	54	16	0.638	40.0
127x76x13	13.0	127.0	76.0	4.0	7.6	7.6	96.6	3.74	24.2	4	46	16	0.537	41.4

Advance and UKB are trademarks of Corus. A fuller description of the relationship between Universal Beams (UB) and the Advance range of sections manufactured by Corus is given in section 12.

FOR EXPLANATION OF TABLES SEE NOTE 2

BS EN 1993-1-1:2005
BS 4-1:2005

UNIVERSAL BEAMS

Advance UKB

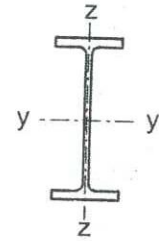

Properties

Section Designation	Second Moment of Area		Radius of Gyration		Elastic Modulus		Plastic Modulus		Buckling Parameter U	Torsional Index X	Warping Constant I_w dm ⁶	Torsional Constant I_T cm ⁴	Area of Section A cm ²
	Axis y-y	Axis z-z	Axis y-y	Axis z-z	Axis y-y	Axis z-z	Axis y-y	Axis z-z					
	cm ⁴	cm ⁴	cm	cm	cm ³	cm ³	cm ³	cm ³					
305x127x48	9570	461	12.5	2.74	616	73.6	711	116	0.873	23.3	0.102	31.8	61.2
305x127x42	8200	389	12.4	2.70	534	62.6	614	98.4	0.872	26.5	0.0846	21.1	53.4
305x127x37	7170	336	12.3	2.67	471	54.5	539	85.4	0.872	29.7	0.0725	14.8	47.2
305x102x33	6500	194	12.5	2.15	416	37.9	481	60.0	0.867	31.6	0.0442	12.2	41.8
305x102x28	5370	155	12.2	2.08	348	30.5	403	48.4	0.859	37.3	0.0349	7.40	35.9
305x102x25	4460	123	11.9	1.97	292	24.2	342	38.8	0.846	43.4	0.027	4.77	31.6
254x146x43	6540	677	10.9	3.52	504	92.0	566	141	0.891	21.1	0.103	23.9	54.8
254x146x37	5540	571	10.8	3.48	433	78.0	483	119	0.890	24.3	0.0857	15.3	47.2
254x146x31	4410	448	10.5	3.36	351	61.3	393	94.1	0.879	29.6	0.0660	8.55	39.7
254x102x28	4000	179	10.5	2.22	308	34.9	353	54.8	0.873	27.5	0.0280	9.57	36.1
254x102x25	3410	149	10.3	2.15	266	29.2	306	46.0	0.866	31.4	0.0230	6.42	32.0
254x102x22	2840	119	10.1	2.06	224	23.5	259	37.3	0.856	36.3	0.0182	4.15	28.0
203x133x30	2900	385	8.71	3.17	280	57.5	314	88.2	0.882	21.5	0.0374	10.3	38.2
203x133x25	2340	308	8.56	3.10	230	46.2	258	70.9	0.876	25.6	0.0294	5.96	32.0
203x102x23	2100	164	8.46	2.36	207	32.2	234	49.7	0.888	22.4	0.0154	7.02	29.4
178x102x19	1360	137	7.48	2.37	153	27.0	171	41.6	0.886	22.6	0.0099	4.41	24.3
152x89x16	834	89.8	6.41	2.10	109	20.2	123	31.2	0.890	19.5	0.00470	3.56	20.3
127x76x13	473	55.7	5.35	1.84	74.6	14.7	84.2	22.6	0.894	16.3	0.00200	2.85	16.5

Advance and UKB are trademarks of Corus. A fuller description of the relationship between Universal Beams (UB) and the Advance range of sections manufactured by Corus is given in section 12.

FOR EXPLANATION OF TABLES SEE NOTE 3

BS EN 1993-1-1:2005
BS 4-1:2005

UNIVERSAL COLUMNS

Advance UKC

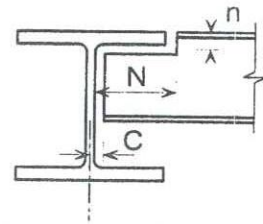
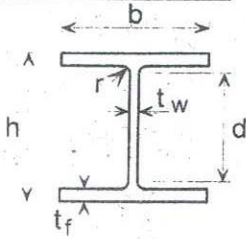

Dimensions

Section Designation	Mass per Metre kg/m	Depth of Section h mm	Width of Section b mm	Thickness		Root Radius r mm	Depth between Fillets d mm	Ratios for Local Buckling		Dimensions for Detailing			Surface Area	
				Web tw mm	Flange tf mm			Flange cf / tf	Web cw / tw	End Clearance C mm	Notch		Per Metre m ²	Per Tonne m ²
											N mm	n mm		
356x406x634	633.9	474.6	424.0	47.6	77.0	15.2	290.2	2.25	6.10	26	200	94	2.52	3.98
356x406x551	551.0	456.6	418.5	42.1	67.5	15.2	290.2	2.56	6.89	23	200	84	2.47	4.48
356x406x467	467.0	436.6	412.2	35.8	58.0	15.2	290.2	2.98	8.11	20	200	74	2.42	5.18
356x406x393	393.0	419.0	407.0	30.6	49.2	15.2	290.2	3.52	9.48	17	200	66	2.38	6.06
356x406x340	339.9	406.4	403.0	26.6	42.9	15.2	290.2	4.03	10.9	15	200	60	2.35	6.91
356x406x287	287.1	393.6	399.0	22.6	36.5	15.2	290.2	4.74	12.8	13	200	52	2.31	8.05
356x406x235	235.1	381.0	394.8	18.4	30.2	15.2	290.2	5.73	15.8	11	200	46	2.28	9.70
356x368x202	201.9	374.6	374.7	16.5	27.0	15.2	290.2	6.07	17.6	10	190	44	2.19	10.8
356x368x177	177.0	368.2	372.6	14.4	23.8	15.2	290.2	6.89	20.2	9	190	40	2.17	12.3
356x368x153	152.9	362.0	370.5	12.3	20.7	15.2	290.2	7.92	23.6	8	190	36	2.16	14.1
356x368x129	129.0	355.6	368.6	10.4	17.5	15.2	290.2	9.4	27.9	7	190	34	2.14	16.6
305x305x283	282.9	365.3	322.2	26.8	44.1	15.2	246.7	3.00	9.21	15	158	60	1.94	6.86
305x305x240	240.0	352.5	318.4	23.0	37.7	15.2	246.7	3.51	10.7	14	158	54	1.91	7.96
305x305x198	198.1	339.9	314.5	19.1	31.4	15.2	246.7	4.22	12.9	12	158	48	1.87	9.44
305x305x158	158.1	327.1	311.2	15.8	25.0	15.2	246.7	5.30	15.6	10	158	42	1.84	11.6
305x305x137	136.9	320.5	309.2	13.8	21.7	15.2	246.7	6.11	17.90	9	158	38	1.82	13.3
305x305x118	117.9	314.5	307.4	12.0	18.7	15.2	246.7	7.09	20.6	8	158	34	1.81	15.4
305x305x97	96.9	307.9	305.3	9.9	15.4	15.2	246.7	8.60	24.9	7	158	32	1.79	18.5
254x254x167	167.1	289.1	265.2	19.2	31.7	12.7	200.3	3.48	10.4	12	134	46	1.58	9.46
254x254x132	132.0	276.3	261.3	15.3	25.3	12.7	200.3	4.36	13.1	10	134	38	1.55	11.7
254x254x107	107.1	266.7	258.8	12.8	20.5	12.7	200.3	5.38	15.6	8	134	34	1.52	14.2
254x254x89	88.9	260.3	256.3	10.3	17.3	12.7	200.3	6.38	19.4	7	134	30	1.50	16.9
254x254x73	73.1	254.1	254.6	8.6	14.2	12.7	200.3	7.77	23.3	6	134	28	1.49	20.4
203x203x127 +	127.5	241.4	213.9	18.1	30.1	10.2	160.8	2.91	8.88	11	108	42	1.28	10.0
203x203x113 +	113.5	235.0	212.1	16.3	26.9	10.2	160.8	3.26	9.87	10	108	38	1.27	11.2
203x203x100 +	99.6	228.6	210.3	14.5	23.7	10.2	160.8	3.70	11.1	9	108	34	1.25	12.6
203x203x86	86.1	222.2	209.1	12.7	20.5	10.2	160.8	4.29	12.7	8	110	32	1.24	14.4
203x203x71	71.0	215.8	206.4	10.0	17.3	10.2	160.8	5.09	16.1	7	110	28	1.22	17.2
203x203x60	60.0	209.6	205.8	9.4	14.2	10.2	160.8	6.20	17.1	7	110	26	1.21	20.2
203x203x52	52.0	206.2	204.3	7.9	12.5	10.2	160.8	7.04	20.4	6	110	24	1.20	23.1
203x203x46	46.1	203.2	203.6	7.2	11.0	10.2	160.8	8.00	22.3	6	110	22	1.19	25.8
152x152x51 +	51.2	170.2	157.4	11.0	15.7	7.6	123.6	4.18	11.2	8	84	24	0.935	18.3
152x152x44 +	44.0	166.0	155.9	9.5	13.6	7.6	123.6	4.82	13.0	7	84	22	0.924	21.0
152x152x37	37.0	161.8	154.4	8.0	11.5	7.6	123.6	5.70	15.5	6	84	20	0.912	24.7
152x152x30	30.0	157.6	152.9	6.5	9.4	7.6	123.6	6.98	19.0	5	84	18	0.901	30.0
152x152x23	23.0	152.4	152.2	5.8	6.8	7.6	123.6	9.65	21.3	5	84	16	0.889	38.7

Advance and UKC are trademarks of Corus. A fuller description of the relationship between Universal Columns (UC) and the Advance range of sections manufactured by Corus is given in section 12.

+ These sections are in addition to the range of BS 4 sections.

FOR EXPLANATION OF TABLES SEE NOTE 2

BS EN 1993-1-1:2005
BS 4-1:2005

UNIVERSAL COLUMNS

Advance UKC

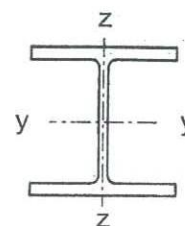

Properties

Section Designation	Second Moment of Area		Radius of Gyration		Elastic Modulus		Plastic Modulus		Buckling Parameter U	Torsional Index X	Warping Constant I_w dm ⁶	Torsional Constant I_T cm ⁴	Area of Section A cm ²
	Axis y-y	Axis z-z	Axis y-y	Axis z-z	Axis y-y	Axis z-z	Axis y-y	Axis z-z					
	cm ⁴	cm ⁴	cm	cm	cm ³	cm ³	cm ³	cm ³					
356x406x634	275000	98100	18.4	11.0	11600	4630	14200	7110	0.843	5.46	38.8	13700	808
356x406x551	227000	82700	18.0	10.9	9960	3950	12100	6060	0.841	6.05	31.1	9240	702
356x406x467	183000	67800	17.5	10.7	8380	3290	10000	5030	0.839	6.85	24.3	5810	595
356x406x393	147000	55400	17.1	10.5	7000	2720	8220	4150	0.837	7.86	18.9	3550	501
356x406x340	123000	46900	16.8	10.4	6030	2330	7000	3540	0.836	8.84	15.5	2340	433
356x406x287	99900	38700	16.5	10.3	5070	1940	5810	2950	0.835	10.17	12.3	1440	366
356x406x235	79100	31000	16.3	10.2	4150	1570	4690	2380	0.834	12.04	9.54	812	299
356x368x202	66300	23700	16.1	9.60	3540	1260	3970	1920	0.844	13.35	7.16	558	257
356x368x177	57100	20500	15.9	9.54	3100	1100	3460	1670	0.844	15.00	6.09	381	226
356x368x153	48600	17600	15.8	9.49	2680	948	2960	1430	0.844	17.01	5.11	251	195
356x368x129	40200	14600	15.6	9.43	2260	793	2480	1200	0.844	19.81	4.18	153	154
305x305x283	78900	24600	14.8	8.27	4320	1530	5110	2340	0.855	7.64	6.35	2030	360
305x305x240	64200	20300	14.5	8.15	3640	1280	4250	1950	0.854	8.73	5.03	1270	306
305x305x198	50900	16300	14.2	8.04	3000	1040	3440	1580	0.854	10.23	3.88	734	252
305x305x158	38700	12600	13.9	7.90	2370	808	2680	1230	0.851	12.46	2.87	378	201
305x305x137	32800	10700	13.7	7.83	2050	692	2300	1050	0.851	14.13	2.39	249	174
305x305x118	27700	9060	13.6	7.77	1760	589	1960	895	0.850	16.14	1.98	161	150
305x305x97	22200	7310	13.4	7.69	1450	479	1590	726	0.850	19.19	1.56	91.2	123
254x254x167	30000	9870	11.9	6.81	2080	744	2420	1140	0.851	8.48	1.63	626	213
254x254x132	22500	7530	11.6	6.69	1630	576	1870	878	0.850	10.32	1.19	319	168
254x254x107	17500	5930	11.3	6.59	1310	458	1480	697	0.848	12.38	0.898	172	136
254x254x89	14300	4860	11.2	6.55	1100	379	1220	575	0.850	14.46	0.717	102	113
254x254x73	11400	3910	11.1	6.48	898	307	992	465	0.849	17.24	0.562	57.6	93.1
203x203x127 +	15400	4920	9.75	5.50	1280	460	1520	704	0.854	7.38	0.549	427	162
203x203x113 +	13300	4290	9.59	5.45	1130	404	1330	618	0.853	8.11	0.464	305	145
203x203x100 +	11300	3680	9.44	5.39	988	350	1150	534	0.852	9.02	0.386	210	127
203x203x86	9450	3130	9.28	5.34	850	299	977	456	0.850	10.20	0.318	137	110
203x203x71	7620	2540	9.18	5.30	706	246	799	374	0.853	11.90	0.250	80.2	90.4
203x203x60	6120	2060	8.96	5.20	584	201	656	305	0.846	14.10	0.197	47.2	76.4
203x203x52	5260	1780	8.91	5.18	510	174	567	264	0.848	15.80	0.167	31.8	66.3
203x203x46	4570	1550	8.82	5.13	450	152	497	231	0.847	17.70	0.143	22.2	58.7
152x152x51 +	3230	1020	7.04	3.96	379	130	438	199	0.848	10.10	0.061	48.8	65.2
152x152x44 +	2700	860	6.94	3.92	326	110	372	169	0.848	11.50	0.050	31.7	56.1
152x152x37	2210	706	6.85	3.87	273	91.5	309	140	0.848	13.30	0.040	19.2	47.1
152x152x30	1750	560	6.76	3.83	222	73.3	248	112	0.849	16.00	0.031	10.5	38.3
152x152x23	1250	400	6.54	3.70	164	52.6	182	80.1	0.840	20.70	0.021	4.63	29.2

Advance and UKC are trademarks of Corus. A fuller description of the relationship between Universal Columns (UC) and the Advance range of sections manufactured by Corus is given in section 12.

+ These sections are in addition to the range of BS 4 sections.

FOR EXPLANATION OF TABLES SEE NOTE 3

BS EN 1993-1-1:2005
BS EN 10210-2:2006

HOT-FINISHED RECTANGULAR HOLLOW SECTIONS

Celsius® RHS

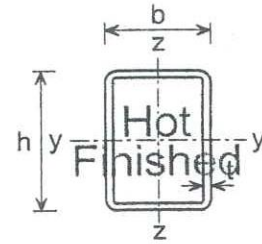

Dimensions and properties

Section Designation		Mass per Metre	Area of Section	Ratios for Local Buckling		Second Moment of Area		Radius of Gyration		Elastic Modulus		Plastic Modulus		Torsional Constants		Surface Area	
Size	Thickness			$c_w/t^{(1)}$	$c_f/t^{(1)}$	Axis y-y	Axis z-z	Axis y-y	Axis z-z	Axis y-y	Axis z-z	Axis y-y	Axis z-z	I_T	W_t	Per Metre	Per Tonne
$h \times b$ mm	t mm	kg/m	A cm^2			cm^4	cm^4	cm	cm	cm^3	cm^3	cm^3	cm^3	cm^4	cm^3	m^2	m^2
160x80	4.0	14.4	18.4	37.0	17.0	612	207	5.77	3.35	76.5	51.7	94.7	58.3	493	88.1	0.470	32.6
	5.0	17.8	22.7	29.0	13.0	744	249	5.72	3.31	93.0	62.3	116	71.1	600	106	0.467	26.2
	6.3	22.2	28.2	22.4	9.70	903	299	5.66	3.26	113	74.8	142	86.8	730	127	0.464	20.9
	8.0	27.6	35.2	17.0	7.00	1090	356	5.57	3.18	136	89.0	175	106	883	151	0.459	16.6
	10.0	33.7	42.9	13.0	5.00	1280	411	5.47	3.10	161	103	209	125	1040	175	0.454	13.5
200x100	5.0	22.6	28.7	37.0	17.0	1500	505	7.21	4.19	149	101	185	114	1200	172	0.587	26.0
	6.3	28.1	35.8	28.7	12.9	1830	613	7.15	4.14	183	123	228	140	1480	208	0.584	20.8
	8.0	35.1	44.8	22.0	9.50	2230	739	7.06	4.06	223	148	282	172	1800	251	0.579	16.5
	10.0	43.1	54.9	17.0	7.00	2660	869	6.96	3.98	266	174	341	206	2160	295	0.574	13.3
	12.5	52.7	67.1	13.0	5.00	3140	1000	6.84	3.87	314	201	408	245	2540	341	0.568	10.8
200x120	5.0	24.1	30.7	37.0	21.0	1690	762	7.40	4.98	168	127	205	144	1650	210	0.627	26.0
	6.3	30.1	38.3	28.7	16.0	2070	929	7.34	4.92	207	155	253	177	2030	255	0.624	20.7
	8.0	37.6	48.0	22.0	12.0	2530	1130	7.26	4.85	253	188	313	218	2500	310	0.619	16.5
	10.0	46.3	58.9	17.0	9.00	3030	1340	7.17	4.76	303	223	379	263	3000	367	0.614	13.3
	14.2	63.3	80.7	11.1	5.45	3910	1690	6.96	4.58	391	282	503	346	3920	464	0.603	9.53
200x150	8.0	41.4	52.8	22.0	15.8	2970	1890	7.50	5.99	297	253	359	294	3640	398	0.679	16.4
	10.0	51.0	64.9	17.0	12.0	3570	2260	7.41	5.91	357	302	436	356	4410	475	0.674	13.2
250x120	10.0	54.1	68.9	22.0	9.00	5310	1640	8.78	4.88	425	273	539	318	4090	468	0.714	13.2
	12.5	66.4	84.6	17.0	6.60	6330	1930	8.65	4.77	506	321	651	381	4880	549	0.708	10.7
	14.2	74.5	94.9	14.6	5.45	6960	2090	8.56	4.70	556	349	722	421	5360	597	0.703	9.44
250x150	5.0	30.4	38.7	47.0	27.0	3360	1530	9.31	6.28	269	204	324	228	3280	337	0.787	25.9
	6.3	38.0	48.4	36.7	20.8	4140	1870	9.25	6.22	331	250	402	283	4050	413	0.784	20.6
	8.0	47.7	60.8	28.3	15.8	5110	2300	9.17	6.15	409	306	501	350	5020	506	0.779	16.3
	10.0	58.8	74.9	22.0	12.0	6170	2760	9.08	6.06	494	367	611	426	6090	605	0.774	13.2
	12.5	72.3	92.1	17.0	9.00	7390	3270	8.96	5.96	591	435	740	514	7330	717	0.768	10.6
	14.2	81.1	103	14.6	7.56	8140	3580	8.87	5.88	651	477	823	570	8100	784	0.763	9.41
250x200	10.0	66.7	84.9	22.0	17.0	7610	5370	9.47	7.95	609	537	731	626	9890	835	0.874	13.1
	12.5	82.1	105	17.0	13.0	9150	6440	9.35	7.85	732	644	888	760	12000	997	0.868	10.6
	14.2	92.3	118	14.6	11.1	10100	7100	9.28	7.77	809	710	990	846	13300	1100	0.863	9.35
260x140	5.0	30.4	38.7	49.0	25.0	3530	1350	9.55	5.91	272	193	331	216	3080	326	0.787	25.9
	6.3	38.0	48.4	38.3	19.2	4360	1660	9.49	5.86	335	237	411	267	3800	399	0.784	20.6
	8.0	47.7	60.8	29.5	14.5	5370	2030	9.40	5.78	413	290	511	331	4700	488	0.779	16.3
	10.0	58.8	74.9	23.0	11.0	6490	2430	9.31	5.70	499	347	624	402	5700	584	0.774	13.2
	12.5	72.3	92.1	17.8	8.20	7770	2880	9.18	5.59	597	411	756	485	6840	690	0.768	10.6
	14.2	81.1	103	15.3	6.86	8560	3140	9.10	5.52	658	449	840	537	7560	754	0.763	9.41
300x100	8.0	47.7	60.8	34.5	9.50	6310	1080	10.2	4.21	420	216	546	245	3070	387	0.779	16.3
	10.0	58.8	74.9	27.0	7.00	7610	1280	10.1	4.13	508	255	666	296	3680	458	0.774	13.2
	14.2	81.1	103	18.1	4.04	10000	1610	9.85	3.94	669	321	896	390	4760	578	0.763	9.41

Celsius® is a trademark of Corus. A fuller description of the relationship between Hot Finished Rectangular Hollow Sections (HFRHS) and the Celsius® range of sections manufactured by Corus is given in section 12.

(1) For local buckling calculation $c_w = h - 3t$ and $c_f = b - 3t$.

Check availability

FOR EXPLANATION OF TABLES SEE NOTES 2 AND 3

BS EN 1993-1-1:2005
BS 4-1:2005

TWO PARALLEL FLANGE CHANNELS BACK TO BACK

TWO Advance UKPFC BACK TO BACK

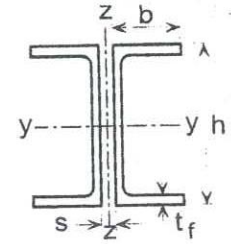

Dimensions and properties

Composed of Two Channels	Total Mass per Metre kg/m	Total Area cm ²	Properties about Axis y-y				Radius of Gyration i_z about Axis z-z (cm)				
			I_y cm ⁴	i_y cm	$W_{el,y}$ cm ³	$W_{pl,y}$ cm ³	Space between webs, s (mm)				
							0	8	10	12	15
430x100x64	129	164	43900	16.3	2040	2440	3.96	4.23	4.31	4.38	4.49
380x100x54	108	137	30100	14.8	1580	1870	4.14	4.42	4.49	4.57	4.68
300x100x46	91.1	116	16500	11.9	1100	1280	4.37	4.66	4.73	4.81	4.92
300x90x41	82.8	105	14400	11.7	962	1140	3.80	4.08	4.16	4.23	4.35
260x90x35	69.7	88.8	9460	10.3	727	849	3.93	4.22	4.29	4.37	4.48
260x75x28	55.2	70.3	7240	10.1	557	656	3.11	3.40	3.47	3.55	3.66
230x90x32	64.3	81.9	7040	9.27	612	709	4.09	4.38	4.46	4.53	4.65
230x75x26	51.3	65.4	5500	9.17	478	557	3.29	3.58	3.66	3.73	3.85
200x90x30	59.4	75.7	5050	8.16	505	583	4.25	4.55	4.63	4.71	4.83
200x75x23	46.9	59.7	3930	8.11	393	454	3.44	3.74	3.82	3.89	4.01
180x90x26	52.1	66.4	3640	7.40	404	464	4.29	4.59	4.67	4.75	4.87
180x75x20	40.7	51.8	2740	7.27	304	352	3.39	3.68	3.76	3.84	3.95
150x90x24	47.7	60.8	2320	6.18	310	357	4.39	4.69	4.77	4.85	4.98
150x75x18	35.7	45.5	1720	6.15	230	264	3.52	3.82	3.90	3.98	4.10
125x65x15	29.5	37.6	966	5.07	155	180	3.05	3.36	3.44	3.52	3.64
100x50x10	20.4	26.0	415	4.00	83.1	97.7	2.34	2.65	2.73	2.82	2.94

Advance and UKPFC are trademarks of Corus. A fuller description of the relationship between Parallel Flange Channels (PFC) and the Advance range of sections manufactured by Corus is given in section 12.

Properties about y axis:

$$I_z = (\text{Total Area}) \cdot (i_z)^2$$

$$W_{el,z} = I_z / (b + 0.5s)$$

where s is the space between webs.

FOR EXPLANATION OF TABLES SEE NOTES 2 AND 3