



UNIVERSITY OF RUHUNA

Faculty of Engineering

Mid-Semester 7 Examination in Engineering: June 2014

Module Number: EE7240

Module Name: Power System Analysis

[Two Hours]

[Answer all questions]

-
- Q1 a) i) What is meant by fault and fault level in a power system?
ii) Why do we need to study of fault analysis in power systems? [2.0 Marks]
- b) Consider the power system shown in Figure Q1 b). If a symmetrical fault occurs at 480 V bus bar,
i) find the fault current at the bus bar by using per unit method.
ii) calculate the fault current contribution from generator 2 and motor 2.
Select $S_{base} = 20$ MVA. [4.0 Marks]
- c) Using the MVA method, calculate the fault currents mentioned in Q1 b) parts i) and ii) [4.0 Marks]
- Q2 a) Explain, what is meant by "Symmetrical components" with reference to an unbalanced three-phase system. [1.0 Mark]
- b) In a three-phase power system, if a double line to ground fault occurs through fault impedance (Z_f), show that current through the fault impedance (Z_f) is three times the zero sequence current. [1.0 Mark]
- c) Two 11 kV, 20 MVA, three-phase, star connected generators operate in parallel. The positive, negative and zero sequence reactances of each being, $j0.18$ pu, $j0.15$ pu and $j0.10$ pu, respectively. The star point of one of the generators is isolated and that of the other is solidly grounded. A double line-to-ground fault occurs on terminals of one of the generators. Assume fault is solid ($Z_f = 0$).
i) Calculate fault current in each phase.
ii) Find the voltage of the healthy phase. [3.0 Marks]
- Q3 a) Briefly explain steady-state stability and transient stability of a power system. [1.0 Mark]
- b) Obtain the swing equation for a system where two generators swinging coherently. [1.0 Mark]

- c) A four-pole synchronous generator rated for 11 kV, 100 MVA, 50 Hz has an inertia constant of 8.0 MJ/MVA.
- Find the stored energy in the rotor at synchronous speed.
 - Find rotor acceleration, if the mechanical input is suddenly raised to 80 MW for an electrical load of 50 MW. Assume that mechanical and electrical losses are negligible.
 - If the acceleration calculated in Q3 c) ii) is maintained for 10 cycles, find the change in torque angle and rotor speed in rpm at the end of this period.

[3.0 Marks]

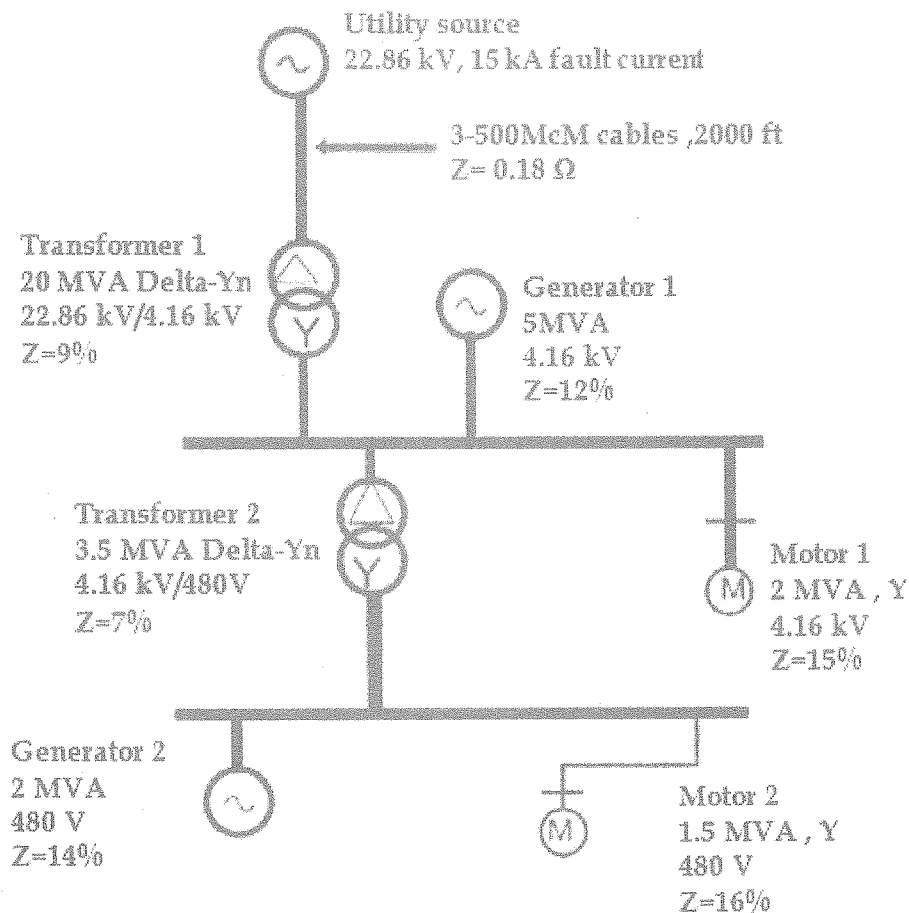

Figure Q1 b)