



UNIVERSITY OF RUHUNA

Faculty of Engineering

End-Semester 4 Examination in Engineering: February 2020

Module Number: ME4305

Module Name: Mechanics of Machines

[Three Hours]

[Answer all questions, each question carries 12 marks]

Clearly state all the assumptions that you may make.

To get full marks, make sure that you have answered with correct SI units and standard notations

- Q1.** a) A mechanism is a combination of various links which are capable of having relative motion with respect to one another. An automobile is equipped with such many mechanisms for various purposes.
- List 4 different mechanical transformations possible with a mechanism.
 - Briefly describe four mechanisms available in a typical automobile related to each transformation listed above (i).
- [4.0 Marks]
- b) A mixer shown in **Figure Q1(b)** consists of a spatula, a wheel, a guide, a frame and a hemispherical shape mixing tank. The mixing tank is rigidly fixed to the frame. The spatula is connected to the wheel at **A** such that it can rotate only about **A** while translating through the guide at **B**, which is connected to the frame. The guide can only rotate about **B** so that the lower end of the spatula makes a mixing path as shown. All the dimensions are given in the diagram is in centimetres (cm). The wheel rotates about **P** counter-clockwise with a constant angular velocity (ω_2) of 100 rpm.
- Draw the skeleton diagram for the configuration of the mechanism shown by considering it is as a planar mechanism where **AP** is perpendicular to **BP** and the mechanism symmetrically operates about vertical line **BP**.
 - Calculate the velocity of extreme point **C** of the spatula.
 - Calculate the acceleration of point **C**.
- [8.0 Marks]
- Q2.** In a mechanism, it is important to determine the acceleration of a links because acceleration produces inertia forces in the links which stress components of the mechanism.
- Obtain acceleration of one end of the link that rotates relative to the other end with an angular speed, ω and angular acceleration, α using centripetal and tangential acceleration components.
- [2.5 Marks]
- b) A skeleton diagram of a horizontal single cylinder engine is shown in **Figure Q2(a)**. The mass of the sliding piston is 0.62 kg and the diameter is 80 mm. The gas pressure, 1.2 MPa acting on the piston produces crank rotation of 3000 rpm at the configuration shown. Assuming that the connecting rod and the crank have negligible inertia and friction.

- i) Draw the velocity diagram and determine the velocity of the piston.
- ii) Draw the acceleration diagram and determine the acceleration of the piston.
- iii) Calculate the inertia force acting on the piston and hence obtain the effective turning moment acting on the crank.

[7.0 Marks]

- c) The Grashof condition is a relationship that predicts the rotational behaviour of the inversion of a four-bar linkage.

- i) States the Grashof law based on the length of links of four-bar mechanism.
- ii) Sketch four possible Grashof mechanisms and clearly indicate the input and output links.

[2.5 Marks]

Q3. A flywheel is a mechanical device which stores energy in the form of rotational momentum.

- a) Explain two main uses of flywheels by giving suitable applications.

[2.0 Marks]

- b) Using standard notations, for a flywheel that is connected, attached to a four-stroke engine, state

- i) coefficient of fluctuation of speed (ϕ) and
- ii) coefficient of fluctuation of energy value (β).
- iii) Obtain a relationship for radius of gyration (k) of the flywheel with mass M .

[4.0 Marks]

- c) A flywheel of a stamping tool is a solid disc that made out of steel. The mean speed of the flywheel is obtained at 60 rev/minutes. This stamping tool is operated once an every 5 revolutions and a torque of 2100 Nm is exerted on the tool for duration of 0.05 seconds. If the disc thickness and the diameter are 100 m and 700 m respectively and density of steel is 7850 kg/m³.

Sketch the torque angle diagram and determine the,

- i) the moment of inertia of the flywheel,
- ii) the work done during the pressing operation,
- iii) the coefficient of fluctuation of speed, and
- iv) the minimum and the maximum speed of the flywheel.

[6.0 Marks]

- Q4.** a) For a gearbox having input torque T_1 and output torque T_2 in the same direction of input, show that the magnitude of the holding torque is given by

$$T_2 \left(1 + \frac{1}{\eta GR} \right)$$

where η is the efficiency of the gearbox and GR represents the gear ratio.

[2.0 Marks]

- b) A compound gear train shown in the **Figure Q4(b)** consists of 4 gears; A, B, C and D. The input gear A revolves clockwise at 900 rpm as viewed from the left end. If the input torque is 30 Nm and the efficiency of the gear train is 80%, determine,

- i) the output power, and
- ii) the holding torque of the gear train.

[4.0 Marks]

- c) An epicyclic gear box has a fixed sun gear D. Gear C is the internal gear with 420 teeth. Two planet gears represented by B in the figure have 140 teeth each. The input (arm/cage A) supplies 7 kW power and the output must deliver 5 kW of power at 900 rpm. Calculate,
- the gearbox ratio,
 - the input speed and its direction,
 - the efficiency of the gearbox.

[6.0 Marks]

- Q5** a) The balancing of rotating bodies is important to avoid vibrations that are noisy and uncomfortable. In heavy industrial machines vibrations could cause catastrophic failures. Briefly describe the things to be satisfied for a body to be completely balanced.

[3.0 Marks]

- b) The **Figure Q5(b)** shows a rotor lying on the z axis whose total length is 1.6 m. The rotor is supported on stiff bearings at $z = 0$ and $z = 1.2$ m. Three discs A, B and C are fixed to the rotor and the mass centre of each is slightly eccentric. The angular positions of weights measured (clockwise) from vertical axis are 120° , 15° and -45° as in the right side of the diagram. **Table Q5(b)** shows the position of the discs and details of the imbalance carried initially on each of the discs.

- Compute the unbalance moment on the bearing 1 when the rotor is spinning at 800 rpm.
(Hint: Assume that the rotor is rigid and make a reference plane through the bearing 1)
- Determine the appropriate imbalance corrections (in kg.mm) to be applied at discs A and C.
- If the radius of the imbalance masses to be added, given as 20 mm for each disc A and C, determine the amount of each mass.

[9.0 Marks]

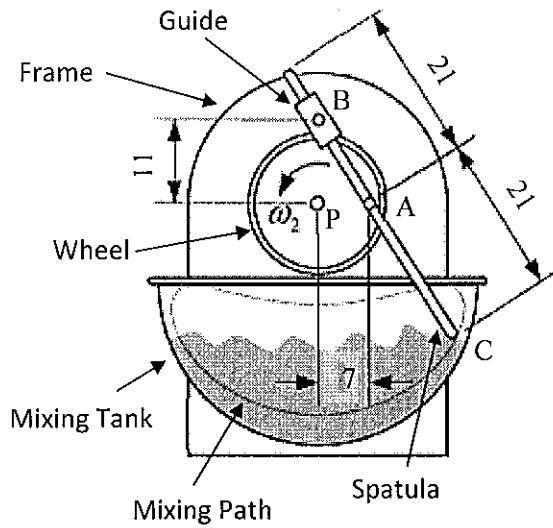

Figure Q1(b)

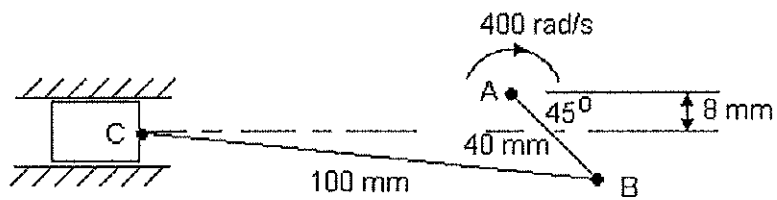

Figure Q2(a)

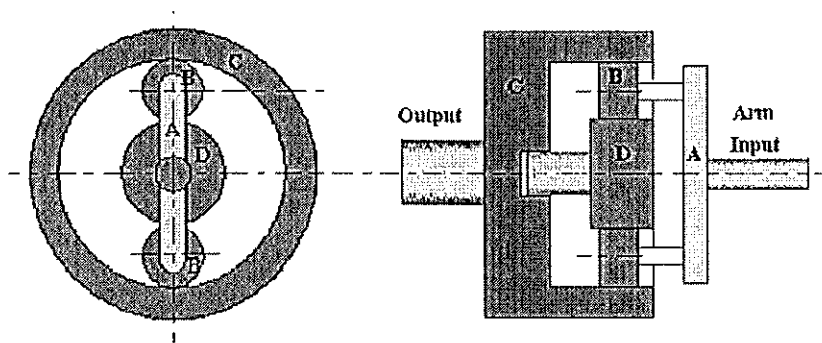

Figure Q4(b)

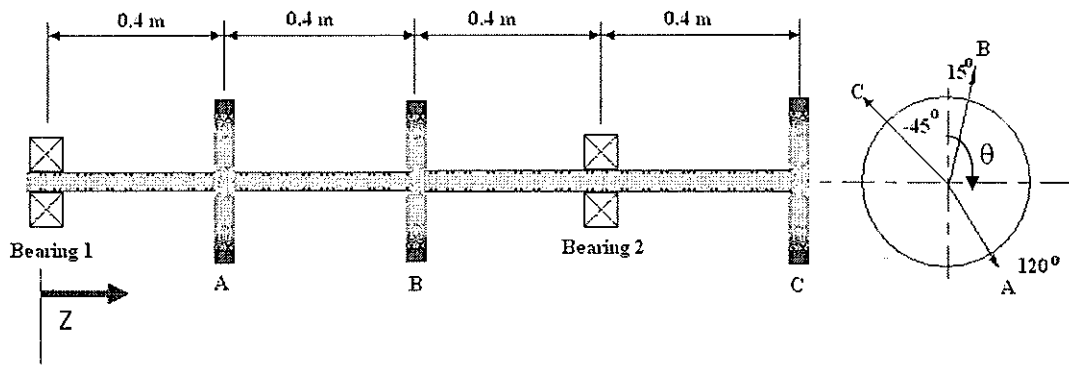

Figure Q5(b)

Table Q5(b)

Disc	Z (m)	M (kg)	Eccentricity (radial distance measured from the disc centre) (m)	θ (deg.)
A	0.4	10	0.15	120
B	0.8	50	0.1	15
C	0.16	20	0.2	-45

Gear A has 50 teeth
Gear B has 150 teeth
Gear C has 30 teeth
Gear D has 60 teeth

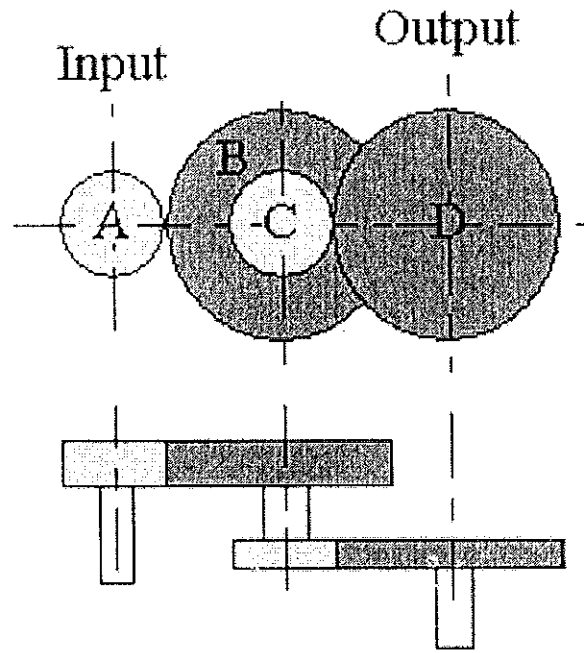

Figure Q4(b)