

Motives of Customer Loyalty in Supermarket Patronage in Sri Lanka

A.C. Karunaratna

University of Ruhuna

Abstract

The supermarket concept has led to a renewed interest among shoppers in the contemporary retailing context. The study was conducted to understand the nature of supermarket patronage in the Sri Lankan context and evaluate the motives behind the choice of supermarket patronage and how those motives impact on customer loyalty. The study is quantitative in nature and the conclusive research design was adopted. Customer survey was conducted to collect data from customers who reside in two major provinces of Western and Southern in Sri Lanka. Data were collected in two stages from two different samples to identify the motives of supermarket patronage and validate the results. The descriptive results provide valuable insight towards the different preferences of male versus female shoppers in supermarket patronage. An exploratory factor analysis was employed for the purpose of identifying key motives of supermarket patronage by shoppers. The results produced three major dimensions which were labelled as 'product motive', 'services motive' and 'atmospheric motive'. The structural equation modeling technique was employed to test the impact of motives on customer loyalty. The results are decisive which indicate that all three motives have significant impact on loyalty where the atmospheric motive has the highest impact on loyalty compared to product and services motives.

Key words:

Customer Loyalty, Shopping Motives, Supermarket Patronage

Corresponding Author:

A.C. Karunaratna, Department of Marketing, University of Ruhuna, Sri Lanka; E-mail: acruhuna@gmail.com

Introduction

In the contemporary marketplace, evaluating the nature of customer behaviour has drawn a renewed interest compared to the past few decades (Seng, 2019; Slack, Singh, & Sharma, 2020; Kanakaratne, Bray, & Robson, 2020). During this decade, significant changes were made in the retailing context such as global brands presence, service sector dominance, a higher weight of direct marketing application, reintermediation, industry convergence and deregulations etc. (Keller, Parameswaran, & Jacob, 2012; Guo, Heinberg, & Zou, 2019; Nie & Wang, 2021; Abbu & Gopalakrishna, 2021) which have severely affected to shape customer behaviour. In the retailing context, retailers compete with one another for the share of wallet of the customers. Currently, the retailing environment has created many opportunities for food firms and farmers (Neven et al., 2006). Especially, the supermarket concept has become very popular in the Asian region as an essential part of the retailing (Orel & Kara, 2014). Accordingly, in the contemporary retailing context, supermarkets are treated as major shopping destinations where customers often visit to purchase necessary consumption materials and fulfill requirements (Rishi & Singh, 2012). At current, within the Sri Lankan retailing context, the concept of supermarket has become so attractive as a popular shopping destination where shoppers enjoy the self-service over traditional retail stores. Consequently, this study was mainly focused on understanding the nature of the behaviour and shopping motives of supermarket shoppers and assessing the level of impact on customer loyalty in supermarket patronage.

In the current society, the needs of consumers have drastically increased than ever in the history where their thinking pattern, decision making and behavioural style as a consumer have significantly changed. Many consumers have shifted from their traditional consumption pattern to the new economic system in the 21st century. In this context of the new economy, the supermarket concept has become popular in Sri Lanka, and stand in the booming stage as an industry while opening outlets islandwide at an accelerated rate. Due to the higher customer demand for grocery items, the growth stage of the life cycle of the supermarket industry became steady in Sri Lanka and currently, it indicates a higher market penetration. Mainly, customers visit supermarkets to purchase fast-moving consumer goods which are essential to consume and fulfill their needs. Especially, in the Sri Lankan retailing context, many customers were used to visit convenience stores to purchase food items for a longer period of time. However, supermarkets have

been attracting many consumers today and consumer patronage has been increased due to the attractive features, benefits and convenience.

Since the supermarkets are evolving as a booming industry, major brands, as well as small scale retailers, enter this market and open new outlets islandwide. The factors such as quality, price, consistency of delivery, and terms of payment have become imperative towards the growing importance of supermarkets (Faiguenbaum et al., 2002). Meanwhile, the main supermarket brands are expanding their chain at a rapid pace since the demand is getting increased. Consumers make visits to supermarkets for purchasing quality products while enjoying a convenient purchasing experience. Due to this higher level of acceptance and loyalty towards supermarkets, this has become an industry which is well-developed in Sri Lanka and it could be identified as a high-velocity industry in the Sri Lankan business arena during the current decade, and customer patronage has been rapidly increased and this has created a new trend. Since a severe competition has existed among the supermarket retailers, they are exploring new strategies and tools to attract and retain shoppers. Moreover, the change in retail environment necessitates the need to manage supermarkets effectively (Mahlangu & Makhitha, 2019). Accordingly, understanding the nature of customer behaviour and major shopping motives which influence to increase of supermarket patronage of grocery shoppers is crucial for the success of this business. More importantly, assessing the effect of shopping motives on customer loyalty is much concern since customer loyalty plays a critical role for the success of the business firms today since loyal customers engage in positive word of mouth and repeat patronage (Andreassen & Lindestad, 1998; Yi & Jeon, 2003; Russell-Bennett et al., 2007; Xhema et al., 2018). However, this phenomenon of supermarket patronage has drawn scant attention in the Sri Lankan business context and has not been well-addressed in the marketing literature as well. Therefore, the study was conducted to understanding the nature of customer behaviour in supermarket patronage, evaluating the major shopping motives for supermarket patronage and assessing the level of impact of the shopping motives on customer loyalty among Sri Lankan grocery shoppers.

Literature Review

Evolution and Adoption of Supermarket Concept in the Retailing Context

The supermarket concept is an important element in the retailing context where consumers enjoy shopping and purchasing goods for personal consumption.

According to Berman and Evans (2013, p. 4), “retailing encompasses the business activities involved in selling goods and services to consumers for their personal, family, or household use and it includes every sale to the final consumers.” In general, consumers have a variety of retail institutions and formats both in the contexts of store and non-store for purchasing necessary consumer materials (Oghojafor et al., 2012; Berman & Evans, 2013). Among the various types of retail institutions, the supermarket concept became very popular during the last decade among grocery shoppers as a place to purchase food and other necessary fast-moving goods. Currently, the supermarket industry is evolving as a booming industry as the means of attracting more and more customers and supermarkets being one of the major destinations for shopping (Rishi & Singh, 2012).

At the early stage, the target customers of the supermarkets were affluent customers and customers who have relatively high social, cultural and educational background. However, it has gradually been changing and currently, supermarkets have gone beyond the upper-income consumers to penetrate the mass market mostly targeting the medium income people in many countries (Neven et al., 2006). This is confirmed by Rishi & Singh (2012) in the Indian retailing settings. Thus, among the regions of developing countries, the Latin American countries have adopted fast and achieved a higher level of growth of supermarket. According to Rishi and Singh (2012), rising incomes, multiple income households, exposure to international lifestyles and media, easier financial credit and an upbeat economy are identified as enhancing aspirations and consumption patterns. Increase of per capita income, the rapid rise of the middle class, increased demand for processed foods, growing access to public transportation and ownership of private vehicles, and increased store capacity through refrigerators and other instruments that encourages customers to shift from daily shopping to weekly or monthly shopping are some of such capacity variables to increase the demand for supermarket services among the customers in developing regions in Asia, Africa and Latin America. Meanwhile, foreign direct investments and revolution in retail procurement logistics technology and inventory management were crucial to increase the supply side of the supermarket services (Reardon et al., 2003).

Motives of Supermarket Patronage

Moutinho et al., (2001) conducting a study to evaluate supermarket shopping behaviour of supermarket consumers in the UK, report that the most satisfied and high-spending customers tend to be those who have the income to take full

advantage of the choice and quality offered where the other customers are more concerned with prices being reasonable and discounts available but the satisfaction of those shoppers is also linked with store atmosphere. Conducting a study to evaluate the shopping motives of customers, Jin and Kim (2003) have segmented shoppers based on their shopping motives in patronizing discount stores into four segments labelled as leisurely-motivated shoppers, socially motivated shoppers, utilitarian shoppers and shopping-apatetic shoppers. Westbrook and Black (1985) underlying the motivation for shopping, identify seven motives such as anticipated utility, role enactment, negotiation, choice optimization, affiliation, power/authority and stimulation that motivate consumers for shopping. Rishi and Singh (2012) have conducted a study to investigate the determinants of supermarket shopping behaviour in the Indian context as an emerging market and presented three factors which which affect shopping behaviour. The study reveals that the physical factors including discounts, quality, local brands, display and visual appeal, social factors comprising salesmen behaviour and choice of children, and the temporal factors which involve open space should be considered in designing marketing strategy for supermarket consumers. According to Mahlangu and Makhitha (2019), customers visit supermarkets for gratification shopping, value shopping, good service and product quality, social shopping and brand hunting.

Thomas and Garland (1993) declare that the presence of a written list on a shopping trip to the supermarket is tangible evidence of out of store planning by the shopper, and this pre-planning may influence both time spent in store and expenditure. Accordingly, Thomas and Garland (1993) have conducted a study comparing two groups of consumers, one with a list and one without. The results are conclusive where written shopping lists have significantly reduced average expenditure and the presence of children accompanying the shopper has significantly increased expenditure and time spent. Oghojafor et al., (2012) have conducted a study to evaluate the women preference as customers to choose supermarket versus open market. The results have reported that 62 per cent of women customers prefer supermarket over the open market as a shopping outlet and main attributes such as quality, price, location, cleanliness, product assortment and parking space have been identified as determinants of preference.

Gidlof et al., (2017) identify both internal and external factors that affect consumer behaviour. Product packages and displays contain a number of features and attributes tailored to catch consumers' attention, which are called external

factors comprising the visual saliency, the number of facings, and the placement of each product. Consumers appear to take advantage of visual saliency in their decision making, using their knowledge about products' appearance to guide their visual attention towards those that fit their preferences. A consumer also brings a number of goals and interests related to the products and their attributes which are called internal factors including brand preferences, price sensitivity, and dietary inclinations. Bourlakis et al., (2005) identify five factors such as queuing times, choice, value, price awareness and loyalty points which affect grocery shopping behaviour. Meanwhile, Karumba and Ngigi (2018) declare that special discounts, security, cleanliness, product quality and fast customer service significantly influence customers' choice of supermarkets. Terblanche (2018) declares that merchandise assortment, interaction with staff and the internal shop environment and customers' in-shop emotions have a strong relationship with cumulative customer satisfaction. Moreover, Karumba and Ngigi (2018) stress that the supermarkets that have a high level of cleanliness, security, variety and quality products, fast customer service and convenient operational schedules attract a large proportion of customers. Nguyen (2020) recognizes people, products, premises, price, stock, systems and service as key operational factors which are important for customer retention in supermarkets.

Customer Loyalty and Supermarket Patronage

The concept of customer loyalty has drawn a higher interest in the contemporary business context since customer loyalty is treated as one of the best measures of success of an organization (Nyadzayo & Khajehzadeh, 2016). Customer loyalty means an intended behaviour towards the services or the company and this includes the likelihood of future renewal of services contracts or the profitability of a change in patronage, how likely the customer is to provide positive word of mouth, or the likelihood of customers providing voice (Andreassen & Lanseng, 1997; Andreassen & Lindestad, 1998). Customer loyalty is emerging as the marketplace currency for the twenty-first century (Singh & Sirdeshmukh, 2000). Since customer loyalty is treated as one of the best measures of success in an organization, the concept of customer loyalty has been drawn a higher interest in the contemporary business context (Nyadzayo & Khajehzadeh, 2016). Customer loyalty means an intended behaviour towards the services or the company and this includes the likelihood of future renewal of services contracts or the profitability of a change in patronage, how likely the customer is to provide positive word of mouth, or the likelihood of customers providing voice (Andreassen & Lanseng, 1997; Andreassen & Lindestad, 1998). Meanwhile,

Oliver (1999, p. 34) defines loyalty as a “deeply held commitment to rebuy or repatronize a preferred product/services consistently in the future, thereby causing repetitive same-brand or same brand-set purchasing, despite situational influences and marketing efforts having the potential to cause switching behaviour.” According to Yi and Jeon (2003), loyalty is repeated purchases of a particular product or service during a certain period of time. Moreover, loyalty is treated as a concept which has its root from the consumer behaviour theory and is something that consumers may exhibit to brands, services or activities (Boohene & Agyapong, 2011).

Although supermarkets provide self-service, the service provision to the customer comprising fresh product area, bakery and cashiers are an important attribute where the service provision includes moments of truth with personnel such as information enquires, guidance to the location of goods, cashiers etc. Moreover, store atmosphere which refers to the environment created by combining a set of visual elements of the physical store environment such as colours, displays, decorative features, ease of movement and stimulation of senses such as smell, condition of the air, music and lighting enables an aesthetic consumer response. The store convenience which refers to a store layout and design that helps customers to plan their shopping trip in terms of orientation and direction is an important attribute of store environmental stimuli (Theodoridis & Chatzipanagiotou, 2009). Self-checkout systems among many different self-service technologies available have become an extremely popular choice of supermarkets around the world where some of the main motivations of the supermarkets for offering self-service systems are cost-cutting, speed and convenience, and those services would enhance customer experience, satisfaction and ultimately loyalty (Orel & Kara, 2014). Meanwhile, Noyan and Simsek (2014) have evidenced that comparative price perceptions, discount perceptions and customer satisfaction have positive direct on customer loyalty and service quality perceptions, product quality perceptions, discount perceptions and value perceptions have an indirect effect on customer loyalty in the supermarket context.

Methodology

The study was conducted to understand the nature of supermarket patronage by Sri Lankan shoppers and evaluate the motives behind the choice of supermarket patronage. This study is quantitative in nature and conclusive research design was adopted. The population consists of supermarket customers who are commonly

termed as supermarket shoppers or grocery shoppers and the sample comprises of supermarket shoppers who reside in the provinces of Western and Southern in Sri Lanka. The study uses the terms of customers and shoppers interchangeably as appropriate in explaining their behaviour and preferences. The data were collected using a structured questionnaire and a customer survey was conducted to collect data. The questionnaire consisted of three parts. The first part of the questionnaire included nine questions with demographic information of the customers and the descriptive information in relation to the nature of visits, preferred days and time, pre-planning, and amount of expenses etc. The second part of the questionnaire was devoted to investigating the key motives of supermarket patronage. Accordingly, it consisted of fifteen attributes which were identified as important elements that encourage customers to visit supermarkets, and the final part comprised of five questions to measure the level of customer loyalty towards supermarkets. The measurement scale which was designed to specify the supermarket motives was derived in referring to Moutinho et al., (2001), Rishi & Singh (2012) and Oghojafor et al., (2012) while the scale to measure customer loyalty was constructed in referring to Oliver (1999), Reichheld et al., (2000), Luarn & Lin (2003) and Watson et al., (2015). The data were collected in two stages to employ exploratory factor analysis and confirmatory factor analysis respectively. Accordingly, two clusters of respondents were selected. At the first stage, the questionnaire was distributed among 500 shoppers. 460 questionnaires were received back reporting 92% response rate. Due to the incompleteness, fourteen questionnaires were rejected, and 446 questionnaires were used for the analysis. For the second stage, a different sample was selected and the questionnaires were distributed among 500 shoppers and 400 duly returned with the response rate of 80%. Exploratory factor analysis was employed with the data collected in the first stage of the study for the purpose of identifying the underlined motives of supermarket patronage and the motives derived from the exploratory factor analysis were validated through structural equation modeling technique with the data collected in the second stage. Accordingly, the next part of the paper presents the results of the study in evaluating the nature of supermarket patronage of shoppers within the context of Sri Lanka.

Data Analysis

The study was conducted to understand the nature of behaviour of shoppers in supermarket patronage and identify the key motives affected on supermarket patronage and how those motives influence on the level of loyalty among

shoppers. The first part of the analysis includes the descriptive statistics of respondents, especially focusing on how shoppers tend to engage in supermarket patronage in relation to the data collected in the first stage. Next, the key variables of the study are analyzed through inferential statistics. The need of data collection at the second stage was aimed at testing the model derived from the first stage of the study. Accordingly, evaluating sample statistics of the respondents was not much concerned in the second stage of the study.

The next part of the analysis provides valuable statistics regarding the customers' preferences towards supermarket patronage and which is analyzed on a comparative basis between male and female customers since the two categories demonstrate different behaviour patterns.

Table 01: Demographic Statistics of the Respondents

Variable	No of Respondents	Percentage (%)
Gender		
Male	226	50.67
Female	220	49.33
Preference of Visits by Days		
Weekdays	186	41.70
Weekend	193	43.28
Both	67	15.02
Preference of Visits by Time		
Morning	123	27.58
Afternoon	72	16.14
Evening	157	35.20
Night	66	14.80
Anytime	28	6.28
Frequency of Visits to Supermarkets		
A few times a week	27	6.05
Twice a week	100	22.42
Once a week	157	35.20
A few times a month	134	30.05
Now and then	28	6.28
Average Expenses of Each Visit		

Below Rs. 2000	13	2.92
Rs. 2000 – Rs. 3999	156	34.98
Rs. 4000 – Rs. 5999	128	28.70
Rs. 6000 – Rs. 7999	65	14.57
Rs. 8000 – Rs. 9999	54	12.11
Rs. 10000 and Above	30	6.72
Ability to Manage Estimated Budget		
Able to manage	72	16.14
Sometimes go over	136	30.50
Always go over	238	53.36
Total	446	100.0

The sample consists of 220 female and 226 male shoppers in the first stage of the data collection. Table 01 shows that 193 customers in the sample prefer to visit supermarkets at weekends while 186 customers prefer to visit on weekdays, and another 67 prefer both, weekdays as well as weekends. This is a good source of information for the operators which means that the supermarkets should be open on weekdays as well as at weekends for the convenience of customers as per their preference.

As shown in table 01, most of the customers prefer to visit supermarket in the evening (between 04:00 p.m. – 7:00 p.m.) as convenient time while the second highest is preferred for morning (between 09:00 a.m. – 11:00 a.m.). Meanwhile, 72 customers prefer at noon (between 12:00 noon – 02: 00 p.m.), and another 66 prefer night (between 08:00 p.m. – 10:00 p.m.). Further, 28 customers have no special preference towards the time and they visit every time as per their convenient time schedules.

As far as the frequency of customer visits is considered, most of them prefer to visit once a week. The second highest prefer a few times (2-3 times) a month. Further, 100 customers have responded that they visit twice a week and a low number of customers, for instance, 27 customers, visit a few times a week. Another 28 customers have mentioned that they do not visit regularly, instead, they visit now and then.

According to table 01, it seems that the majority of customers, for instance around 64% altogether, spend on average expense between Rs. 2000 – Rs. 6000.

Meanwhile, there are a few who spend below Rs. 2000. Moreover, 65 customers (15%) spend around Rs. 6000 – Rs. 7999 while 54 customers (12%) spend more than Rs. 8000. Also, another 30 customers (7%) spend over Rs. 10 000 in each visit. Supermarket retailers are really interested in those categories who spend more in each visit and treated them as loyal customers, categorized as either gold customers or platinum customers, and provide more loyal offers and benefits to retain them in long run.

It was asked whether it is able to manage their estimated budget which is intended to spend in each supermarket visit. According to table 01, it shows that only 72 customers, that is 16% of the sample, have expressed such ability. The majority of customers (53%) stated that they are unable to manage the budget and it always goes over than estimated. Moreover, 136 customers (30.5 %) have encountered that estimated budget sometimes go over. This result is a good indicator of poor financial management of customers in terms of family budget and caught by the strategies imposed by supermarket retailers as the means of encouraging shoppers to spend more.

Table 02: Gender Comparison of Shopping Preferences

Variable	Male	Female	Total
Preference of Visits by Days			
Weekdays	123	63	186
Weekend	75	118	193
Both	28	39	67
Preference of Visits by Time			
Morning	53	70	123
Afternoon	30	42	72
Evening	59	98	157
Night	56	10	66
Anytime	28	0	28
Preference of Visits by Alone or with Partner (Husband/Wife)			
Alone	127	66	193
With Partner/Family	99	154	253
Married	182	153	335
Unmarried	44	67	111

Frequency of Visits to Supermarkets			
A few times a week	26	01	27
Twice a week	48	52	100
Once a week	55	102	157
A few times a month	70	64	134
Now and then	27	01	28
Planned Visits versus Unplanned Visits			
Planned	216	219	435
Unplanned	10	01	11
Having a list	110	163	273
Not having a list	116	57	173
Total			
	226	220	446

Table 02 further compares the preferences between male versus female shoppers. Accordingly, the majority of male customers prefer to visit supermarket on weekdays while the majority of female customers prefer to visit at weekends. If supermarket operators are willing to organize a separate customer awareness programmes, promotional campaigns or customer loyalty campaigns targeting either male or female customers, analyzing this nature of behaviour is much important. Meanwhile, there are some customers, both male and female, who prefer weekdays as well as weekends. Moreover, the majority of female shoppers prefer supermarket visits in the evening and morning at weekends while male shoppers have not shown any specific time schedules. Accordingly, male shoppers demonstrate an irregular behaviour of visits which may happen at any time from morning to night as per their needs.

Further, table 02 shows the preference of customers to visit supermarkets either alone or as together with partner (boyfriend/girlfriend or husband/wife) or family. According to the results, the majority of male customers prefer shopping alone while the majority of female customers prefer shopping together with the partner/family. The results reveal an interesting factor that although the majority of men are married, they prefer shopping alone. Almost all the women who are married prefer to do their shopping with the partner.

The supermarket visits of male shoppers seem irregular while female shoppers properly plan it. For instance, the majority of female shoppers (for instance, 102

shoppers) visit supermarket once a week. Further, 52 shoppers make visits twice a week where 64 shoppers visit a few times a month. The number of customer visits from the point of retailers' context is critical for the turnover and profitability of supermarkets. Moreover, the bulk of each item to be maintained is also determined by the number of customers' visits and their level of purchases. Therefore, retailers' attention to be drawn towards these regular and irregular patterns of customer visits would be imperative for the success of their business. Meanwhile, most of the customers except a few have a plan on what to purchase from each visit. However, a list of items to be purchased is prepared by half of male customers only. More importantly, the highest number of female customers prepares a list of items before each visit.

The behavioural patterns and preferences of shoppers discussed in this section are important to be considered by the management and the personnel involved for smoothly functioning of the supermarket operations while satisfying their customers' needs. The next part of the study involves identifying the key motives of supermarket patronage and how those motives impact on the level of loyalty of shoppers.

Exploring the Motives of Supermarket Patronage

Many attributes influence on customers' patronage on supermarket visits. Accordingly, those were explored and fifteen such attributes were identified. Next, an exploratory factor analysis was employed to identify the underlined motives that have an impact on supermarket patronage since exploratory factor analysis is treated as a tool of data reduction technique where it reduces the variables from a fairly large set of observable variables to a smaller more manageable number and pools them together to identify as latent constructs (Conway & Huffcutt, 2003; Matsunaga, 2010; Hair et al., 2014). KMO measure of sampling adequacy for the items is 0.672 and Bartlett's test value is statistically significant (Chi-square = 7912.748, $P < 0.000$) indicating the adequacy of inter-correlations among the items.

Table 03: Exploratory Factor Analysis: Rotated Factor Matrix

Attributes	Components		
	1	2	3
Convenient Operating Hours	.865		
Parking	.862		
Fast Checkout Lines	.856		
Friendly Service	.850		
Comfortable Shopping	.841		
Special Loyal Offers	.824		
Product Quality		.883	
Wider Choice of Products		.866	
Well-known Brands		.846	
Display of Merchandise		.591	
Value for Money		.558	
One-stop Shopping			.949
Clean & Tidy			.935
Store Ambience			.830

Table 03 shows the results of the rotated factor matrix of the exploratory factor analysis. The results indicate that the pool of fifteen attributes has been reduced to fourteen attributes by dropping one item (feeling sense of esteem) and be classified into three major dimensions which are introduced as the motives of supermarket patronage by shoppers. The first dimension consists of six attributes such as convenient operating hours, parking, fast checkout lines, friendly service, comfortable shopping and special loyal offers. This dimension was named as 'services motive' due to the nature of the attributes. The second dimension includes five attributes such as product quality, a wider choice of products, availability of well-known brands, display of merchandise and value for money. Due to the nature of the attributes, this dimension was labelled as 'product motive'. The third dimension specified as 'atmospheric motive' consists of three attributes such as one-stop shopping experience, clean & tidy atmosphere and store ambience.

Table 04: Descriptive and Reliability Statistics of Motives

Motive	Mean Value	Standard Deviation	Reliability (Alpha)	Number of Items
Product	4.42	0.379	0.834	5
Services	4.61	0.424	0.930	6
Atmospherics	4.48	0.471	0.936	3

Table 04 illustrates the descriptive statistics, reliability statistics and number of items for each motive of the supermarket patronage which were developed from the Exploratory Factor Analysis. Accordingly, the three motives have reported Mean value above 4.4 which mean all the attributes which were considered in this study are really important for the supermarket patronage of customers. At the same time, Cronbach's Alpha value has been reported above 0.8 for the 'product motive' and above 0.9 for the 'services motive' and the 'atmospheric motive'. According to the rule of thumb, this confirms that the internal validity of the constructs.

Level of Customer Loyalty towards Supermarket Patronage

The level of loyalty towards supermarkets was evaluated since customer loyalty is treated as a significant factor for the health and the success of an organization in the contemporary competitive business context (Reichheld et al., 2000; Rai & Srivastava, 2012; Watson et al., 2015; Nyadzayo & Khajehzadeh, 2016; Cobelli & Chiarini, 2020).

Table 05: Descriptive Statistics of Customer Loyalty

Factor	Mean	Standard Deviation
Frequent Usage	4.51	0.505
Continuation of Visits	4.53	0.500
Future Shopping Intention	4.69	0.465
Positive Word of Mouth	4.63	0.484
Recommendation	4.50	0.500
Grand Mean	4.57	0.351

For the purpose of measuring loyalty, five key attributes such as frequent usage, continuation of visits, future shopping intention, engagement of positive word of mouth and recommendation to others (Oliver, 1999; Reichheld et al., 2000; Luarn & Lin, 2003; Watson et al., 2015), which are essentially used to measure loyalty in the marketing literature, were used. The results as depicted in table 05 confirm a higher level of loyalty reporting Mean value above 4.5 for all attributes where Grand Mean is reported as 4.57. This further assures a higher level of customer loyalty towards supermarket patronage. Cronbach's Alpha value of the scale items of customer loyalty reported as 0.761 confirming the internal validity of the scale items.

Validating the Model: Motives of Supermarket Patronage on Loyalty

The factor structure derived from the exploratory factor analysis was further assessed through confirmatory factor analysis to validate the results. Confirmatory factor analysis is used as the most direct method of validating the results and assessing the replicability of the results (Schreiber et al., 2006; Byrne, 2010; Hair et al., 2014). Accordingly, the data were collected from a different sample including 400 supermarket customers as the second stage of the study. Next, structural equation modeling analysis was employed to test the impact of the underlined motives on customer loyalty which is depicted in figure 01.

Figure 01: Study Model: The Impact of Shopping Motives on Customer Loyalty

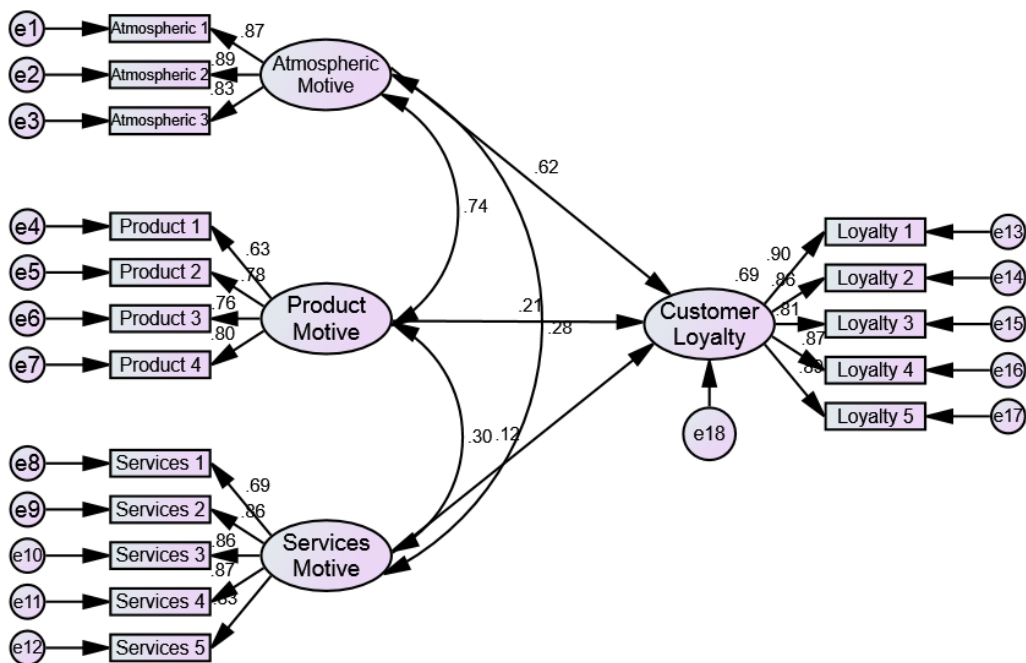

Figure 01 depicts the results of the structural equation modeling analysis. The model χ^2 is significant ($\chi^2 = 507.735$ with 113 degree of freedom). The p -value associated with the result is significant which is to be expected given the large sample size ($N = 400$). Moreover, in case of applying confirmatory factor analysis and structural equation modeling analysis, it considers many fit indices including absolute fit indices, incremental fit indices and parsimony fit indices to validate the model (Hu & Bentler, 1999; Byrne, 2010; Hair et al., 2014). Accordingly, under Absolute Fit Indices, Normed Chi Square value (CMIN/DF) should be below 5. The result of the study reports Normed Chi Square value as 4.493 which is treated as a satisfactory level to proceed the analysis. Moreover, Root Mean Square Error of Approximation (RMSEA) value should be below 0.08 as the threshold value where the study has reported 0.076 which is also satisfactory. Moreover, Goodness of Fit Index (GFI) value is 0.909 which is above 0.9 is also treated as a good indicator. As far as the Incremental Fit Indices are considered, both the Comparative Fit Index (CFI) and Normed Fit Index (NFI) have reported above the threshold value of 0.9 indicating 0.950 (CFI) and 0.936 (NFI) respectively. Moreover, the Adjusted Goodness of Fit Index (AGFI) as the

Parsimony Fit Index indicates the value of 0.877 which is above the threshold value of 0.8. Table 06 includes the summary of the fit indices of the analysis.

Table 06: CFA Fit Indices

Goodness of Fit Indices	Value
Chi Square (χ^2)	507.735 ($P=0.000$)
Degree of freedom	113
Absolute Fit Indices	
Normed Chi Square value (CMIN/DF)	4.493
RMSEA	0.076
Goodness of Fit Index (GFI)	0.909
Incremental Fit Indices	
Comparative Fit Index (CFI)	0.950
Normed Fit Index (NFI)	0.936
Parsimony Fit Index	
Adjusted Goodness of Fit Index (AGFI)	0.877

Table 07 presents the number of scale items of each motive of customer patronage and customer loyalty after conducting the SEM analyses. It further shows that the scale items derived from the exploratory factor analysis have further purified with confirmatory factor analysis. Accordingly, while one item from product motive (i.e., value for money) and services motive (i.e., special loyal offers) dropped, the three scale items of atmospheric motive remained same. Moreover, no change was made to the scale items of customer loyalty and it consists of five items.

Table 07: Study Variables and Scale Items

Study Variables	Scale Items	Item Code	Factor Loading
Atmospheric Motive	One-stop Shopping	Atmospheric 1	.87
	Clean & Tidy	Atmospheric 2	.89
	Store Ambience	Atmospheric 3	.83
Product Motive	Product Quality	Product 1	.63
	Wider Choice of Products	Product 2	.78
	Well-known Brands	Product 3	.76
	Display of Merchandise	Product 4	.80
Services Motive	Convenient Operating Hours	Services 1	.69
	Parking	Services 2	.86
	Fast Checkout Lines	Services 3	.86
	Friendly Service	Services 4	.87
	Comfortable Shopping	Services 5	.83
Customer Loyalty	Frequent Usage	Loyalty 1	.90
	Continuation of Visits	Loyalty 2	.86
	Future Shopping Intention	Loyalty 3	.81
	Positive Word of Mouth	Loyalty 4	.87
	Brand Recommendation	Loyalty 5	.89

Construct Validity and Reliability

It is essential to assess the construct validity of the proposed measurement model (Hu & Bentler, 1999; MacKenzie et al., 2011; Hair et al., 2014). Construct validity refers as “the extent to which a set of measured items actually reflects the theoretical latent construct those items are designed to measure.” (Hair et al., 2014, p. 601). Basically, it is mandatory to assess the validation of a model using convergent validity and discriminant validity (Fornell & Larcker, 1981; Hu & Bentler, 1999; Byrne, 2010; MacKenzie et al., 2011; Hair et al., 2014). Convergent validity, which should be of 0.5 or higher value as the rule of thumb, is assessed involving the items that are indicators of a specific construct converge or share a high proportion of variance in common (Hu & Bentler, 1999; Byrne, 2010; Hair et al., 2014) whereas discriminant validity refers as “a construct is truly distinct from other constructs both in terms of how much it correlates with other constructs and how distinctly variables represent only this single construct.” (Hair et al., 2014, p. 601).

Table 08 depicts the values of Average Variance Extracted (along the diagonal) of each latent construct and correlations (below the diagonal) and squared correlations (above the diagonal). Accordingly, all constructs have reported AVE value above 0.5 confirming the convergent validity. The statistics in table 07 can be further used to assess the discriminant validity of the constructs as well. Discriminant validity can be evaluated by comparing the average variance-extracted values for any two constructs with the squared correlation estimate between the two constructs or comparing the square root of average variance-extracted values with the correlation estimate between the two constructs (Fornell & Larcker, 1981; MacKenzie et al., 2011; Hair et al., 2014). The AVE should be greater than the squared correlation estimates of each construct to confirm the discriminant validity which is also satisfactory.

Table 08: AVE and Correlations among Study Variables

Constructs	Product Motive	Services Motive	Atmospheric Motive	Customer Loyalty
Product Motive	.56	.09	.54	.08
Services Motive	.30	.68	.04	.04
Atmospheric Motive	.74	.21	.75	.52
Customer Loyalty	.28	.21	.72	.75

*Values below the diagonal are correlation estimates among the variables and values above the diagonal are squared correlations, and the values on the diagonal represent the AVE values of the study variables.

The internal consistency among the scale items of a construct commonly known as the reliability has a high weight in social science research and Cronbach Alpha value and Composite Reliability value are treated as the key tools mainly used to measure reliability (Fornell & Larcker, 1981; Raykov, 1997, Cavana et al., 2001; Hair et al., 2007; MacKenzie et al., 2011). Table 09 shows that all constructs are reliable assuring the reliability values above 0.7 and it further confirms very high reliability indicating very high values of Cronbach's Alpha and Composite Reliability values of each variable.

Table 09: Reliability Statistics of the Study

Study Variables	Cronbach Alpha	Composite Reliability	Number of Items
Product motive	0.831	0.832	4
Services Motive	0.911	0.914	5
Atmospheric Motive	0.895	0.898	3
Customer Loyalty	0.938	0.938	5

One of the key objectives of the study is to evaluate the impact of shopping motives on customer loyalty. Accordingly, the structural model has produced satisfactory results. The R^2 value of customer loyalty is 0.69 where the variance of customer loyalty can be successfully predicted by 69% by the motives of customer patronage in terms of product motive, services motive and atmospheric motive. The results of the study are decisive which indicate that the atmospheric motive has the highest impact on loyalty with β value of .622 ($P < 0.05$) while product motive indicating β value of .209 ($P < 0.05$) and services motive representing β value of .119 ($P < 0.05$) are significant predictors of customer loyalty in the context of supermarket patronage. The summary of the results of regression weights as depicted in figure 01 of structural model is shown in table 10.

Table 10: The Results of the Impact of Motives on Customer Loyalty

Study Variables	Customer Loyalty	
	Standardized Regression (β)	Significance Level (P)
Product Motive	.209	.000
Services Motive	.119	.000
Atmospheric Motive	.622	.000

Results and Discussion

Descriptive statistics of the study provide some important insights of the supermarket patronage of customers which would be immensely useful for the marketers in relation to functioning the operations and activities in fulfilling customer requirements. The preferred days, time slots and frequency of visits by customers are critical for smoothly functioning of operations of the supermarkets. Moreover, the bulk of each item to be maintained is also determined by the number of customers' visits and their level of purchases. Also, these patterns of behaviour ultimately determine the turnover and profitability of the supermarkets.

Moreover, these statistics support to understand the preferences of female shoppers over male. Accordingly, the preferences of supermarket visits were evaluated on a comparative basis between male and female shoppers. In case of implementing separate customer awareness programmes, promotional campaigns and customer loyalty campaigns targeting either male or female customers, these results are much important for the management of the supermarket operators.

The majority of male shoppers prefer to visit supermarket on weekdays all the time from morning to night while majority of female shoppers prefer in the evening and morning at weekends. Meanwhile, the majority of female shoppers demonstrates well-arranged shopping trips and prefers to visit supermarket once a week. However, male shoppers demonstrate different preferences. In a nutshell, the supermarket visits of male shoppers seem irregular while female shoppers properly plan it. In case of analyzing the preference of supermarket visits together with partner (boyfriend/girlfriend or husband/wife), it shows that the majority of female shoppers prefer shopping together with the partner (boyfriend/husband) while the majority of male shoppers prefer shopping alone. The interesting feature to be noted here even married male shoppers prefer shopping alone. However, almost all women who are married prefer to do their shopping with the partner.

Meanwhile, most of them except a few have a plan on what to purchase from each visit. More importantly, the highest number of female customers prepares a list of items before each visit. Thomas and Garland (1993) declare that the presence of a written list on a shopping trip may influence both time and expenditure. This study assures that the majority of customers plan their shopping trip having a written list of items where this tendency is quite high from female customers over male customers. Meanwhile, Oghojafor et al., (2012) have evaluated the women preference as customers to choose supermarket versus open market. The results have reported that 62 per cent of women customers prefer supermarket over the open market as a shopping outlet. This study provides evidence that female shoppers are more interested in supermarket shopping. Accordingly, the number of shopping trips to the supermarket is displayed by an irregular pattern from the male customers while well-planned arrangement is demonstrated by female customers.

Oghojafor et al., (2012) have identified main attributes such as quality, price, location, cleanliness, product assortment and parking space as major determinants of preference towards supermarket patronage. The current study also identified

similar factors in the Sri Lankan context. The attributes enjoyed by shoppers are quite same, but the factors were labelled as the 'product motive', 'services motive' and 'atmospheric motive' due to the nature of the attributes of each motive. Gidlof et al., (2017) have identified product packages and displays including visual saliency, the number of facings, and the placement of each product to catch consumers' attention. Meanwhile, Rishi and Singh (2012) have identified physical factors including discounts, quality, local brands, display and visual appeal as the most influential factors affected on supermarket shopping behaviour in the Indian retailing context. Accordingly, the product and its features are considered as a very important motive for supermarket visits. The product quality display of merchandise as the means of well-arranged items in the shelves, availability of wider choice of products and well-known brands, and value for money were identified as important attributes of the product motive which customers are persuaded for supermarket visits.

Meanwhile, the attributes such as parking space (Oghojafor et al., 2012) and salesmen behaviour (Rishi & Singh, 2012) have been identified as important service elements of supermarket patronage. Since the image of a supermarket is strengthened by the associated services along with products delivered to customers, the services attributes play a vital role in enhancing customer loyalty. Accordingly, among many services attributes which can be provided by a supermarket, convenient operating hours, parking space, fast checkout lines, friendly service from employees and comfortable shopping experience were identified as important service attributes which impact on customer loyalty.

According to Theodoridis & Chatzipanagiotou (2009), store atmosphere which refers to the environment created by combining a set of visual elements of the physical store environment such as colours, displays, decorative features, ease of movement and stimulation of senses such as smell, condition of the air, music and lighting enables an aesthetic consumer response. These aesthetic attributes are really important for customer patronage at supermarkets since customers tend to enjoy with them. Accordingly, the 'atmospheric motive' which includes the attributes of store ambience such as store layout, paintings, colour, lightening, music and aroma, clean & tidy atmosphere and one-stop shopping as the tendency of purchasing all consumer products under one-roof has the highest impact on customer loyalty.

Conclusions

The study was mainly focused on understanding the nature of supermarket patronage of shoppers in the retailing context of Sri Lanka and evaluating the motives behind the supermarket patronage and the effect of them on customer loyalty. The study is quantitative in nature and conclusive research design was adopted and a customer survey was conducted to collect data from the customers who reside in the provinces of Western and Southern. Data were collected in two stages. Exploratory factor analysis was employed with the data collected in the first stage of the study for the purpose of identifying the underlined motives of supermarket patronage and the motives derived from the exploratory factor analysis were validated through structural equation modeling technique with the data collected in the second stage.

In addition to appraising the nature of customer behaviour in terms of customer preferences in selecting and managing the days, time, frequency and budget, the study directed to evaluating the key motives of supermarket patronage and how those motives impact on the level of loyalty of shoppers. The results produced three major motives for supermarket patronage. The results are decisive to be noted that all three motives, namely product, services and atmospheric significantly impact on customer loyalty in supermarket patronage.

Managerial Implications

The results of the study are imperative to be used in decision-making to handle the operations of supermarkets. According to the results, shoppers prefer to visit supermarkets weekdays as well as weekends. However, while male shoppers prefer week-days female shoppers prefer weekends. Therefore, it is better to provide the service almost all seven days in the week. As far as the time factor is concerned, the preference ranges from morning to night. Therefore, an interrupted service from morning to night is essential to fulfill customer needs. The majority of male shoppers prefer to visit alone while the majority of female prefer to visit together with partner (husband or family members). The results reveal an interesting feature that although majority of men are married, they prefer to visit supermarkets alone. Almost all the women who are married prefer to do their shopping with the family.

The majority of customers prefer to visit supermarkets once a week, while one third of customers in the sample prefer a few times (2-3 times) a month, and

considerably a low number of customers visit a few times a week. Almost all the customers visit supermarkets having a plan with the decision of what to buy; only half of them prepare a written list of items to be purchased. It seems that the majority of customers spend on average expense between Rs. 2000 – Rs. 6000. Meanwhile, a considerable number of customers, for instance, one third of the sample, spend above Rs. 6000 and around 7% spend over Rs. 10 000 in each visit. Supermarket retailers will be really interested on these categories in launching customer loyalty/reward programmes since they are recognized as either gold customers or platinum customers who are treated as an important asset for a company (Thakur & Workman, 2016). Although many customers prepare a plan and list of items to be purchased, many of them are unable to control their budget and it always go beyond the estimated budget which will be very interesting element for supermarket managers.

The behavioural patterns and preferences of shoppers identified in this study are important and need to be taken into consideration by the management and the personnel of supermarkets for smoothly functioning of the supermarket operations and satisfying customer needs. More importantly, the preferences on supermarket patronage have distinctive differences between male and female shoppers. For instance, while male shoppers demonstrate an irregular behaviour of visits female shoppers demonstrate a well-planned behavioural pattern. If supermarket operators wish to launch customer awareness programmes, promotional campaigns or customer loyalty campaigns targeting either male or female customers, analyzing this nature of behaviour is much important.

The study involved in identifying the key motives of supermarket patronage and how those motives impact on customer loyalty. Accordingly, among the three motives identified in the study, the atmospheric motive which consists of three attributes such as one stop shopping experience, clean & tidy atmosphere and store ambience has the highest significant impact on customer loyalty. It delineates that most of the shoppers enjoy supermarket experience due to its clean & tidy atmosphere and store ambience and accordingly attempt to fulfill most of their FMCG consumption requirements from supermarkets. Next, the product attributes such as the quality of products, wider choice of products, availability of well-known brands and display of merchandise are very important attributes for enhancing the level of loyalty among supermarket shoppers. Finally, services motive which consists of five attributes such as convenient operating hours, parking, fast checkoutlines, friendly service and comfortable shopping also

significantly affects loyalty among shoppers. The practical evidence also supports this claim that many shoppers enjoy product attributes and service attributes in the supermarket context and those are treated as major reasons for the gradual increase of supermarket patronage. Therefore, it can be assured that implementing proper strategies to upgrade the level of those product and service attributes can contribute to enhancing the level of customer loyalty and ultimately increase supermarket patronage.

Declaration of Conflicting Interests

The author declared no potential conflicts of interest with respect to the research, authorship, and publication of this article.

References

- Abbu, H. R., & Gopalakrishna, P. (2021). Synergistic effects of market orientation implementation and internalization on firm performance: Direct marketing service provider industry. *Journal of Business Research*, 125, 851-863.
- Andreassen, W. T., & Lanseng, E. (1997). The Principal's and agents' contribution to customer loyalty within an integrated services distribution channel. *European Journal of Marketing*, 31 (7), 487-503.
- Andreassen, W. T., & Lindestad, B. (1998). Customer loyalty and complex services: The impact of corporate image on quality, customer satisfaction and loyalty for customers with varying degrees of services expertise. *International Journal of Services Industry Management*, 9 (1), 7-23.
- Berman, B., & Evans, J. R. (2013). *Retail Management: A Strategic Approach*, Prentice Hall of India, New Delhi.
- Boohene, R., & Agyapong, G. K. Q. (2011). Analysis of the Antecedents of Customer Loyalty of Telecommunication Industry in Ghana: the Case of Vodafone (Ghana). *Canadian Centre of Science and Education, International Business Research*, 4 (1), 229-240.
- Bourlakis, M., Mamalis, S., & Sangster, J. (2005). Planned versus Unplanned Grocery Shopping Behaviour: An Empirical Study. *The Proceedings of the fifth WSEAS International Conference*, 1- 6.
- Byrne, B. M. (2010). *Structural Equation Modeling with AMOS: Basic Concepts, Applications, and Programming*. Second Edition, New York.
- Cavana, R. Y., Delahaye, B. L., & Sekaran, U. (2001). *Applied Business Research: Qualitative and Quantitative Methods*. Queensland: John Wiley & Sons.

- Cobelli, N., & Chiarini, A. (2020). Improving customer satisfaction and loyalty through mHealth service digitalization. *The TQM Journal*, 32 (6), 1541-1560.
- Conway, J. M., & Huffcutt, A. I. (2003). A Review and Evaluation of Exploratory Factor Analysis Practices in Organizational Research. *Organizational Research Methods*, 6 (2), 147-168.
- Faiguenbaum, S., Berdegue, J. A., & Reardon, T. (2002). The rapid rise of supermarkets in Chile: effects on dairy, vegetable, and beef chains. *Development Policy Review*, 20 (4), 459-471.
- Fornell, C., & Larcker, D. F. (1981). Evaluating Structural Equation Models with Unobservable Variables and Measurement Error. *Journal of Marketing Research*, 18 (1), 39-50.
- Gidlof, K., Anikin, A., Lingonblad, M., & Wallin, A. (2017). Looking is buying. How visual attention and choice are affected by consumer preferences and properties of the supermarket shelf. *Appetite*, 116, 29-38.
- Guo, X., Heinberg, M., & Zou, S. (2019). Enhancing consumer attitude toward culturally mixed symbolic products from foreign global brands in an emerging-market setting: The role of cultural respect. *Journal of International Marketing*, 27 (3), 79-97.
- Hair, J. F., Money, A. H., Samouel, P., & Page, M. (2007), *Research Methods for Business*. John Wiley & Sons, Inc., New Jersey.
- Hair, J. F., Black, W. C., Babin, B. J., & Anderson, R. E. (2014). *Multivariate Data Analysis*. Seventh Edition, Prentice Hall, New Jersey.
- Hu, L., & Bentler, P. M. (1999). Cutoff criteria for fit indexes in covariance structure analysis: Conventional criteria versus new alternatives. *Structural Equation Modeling: A Multidisciplinary Journal*, 6 (1), 1-55.
- Jin, B., & Kim, J. O. (2003). A typology of Korean discount shoppers: shopping motives, store attributes, and outcomes. *International Journal of Service Industry Management*, 14 (4), 396-419.
- Kanakaratne, M. D. S., Bray, J., & Robson, J. (2020). The influence of national culture and industry structure on grocery retail customer loyalty. *Journal of Retailing and Consumer Services*, 54, 102013.
- Karumba, T., & Ngigi, P. (2018). Factors that influence customer choice of supermarkets in Karatina Town-Nyeri Country, Kenya. *Scholars Journal of Economics, Business and Management*, 5 (4), 286-294.
- Keller, K. L., Parameswaran, M. G., & Jacob, I. (2012). *Strategic Brand Management*. Prentice Hall, New Delhi.
- Luar, P., & Lin, H. (2003). A Customer Loyalty Model for E-service Context. *Journal of Electronic Commerce Research*, 4 (4), 156-167.

- MacKenzie, S. B., Podsakoff, P. M., & Podsakoff, N. P. (2011). Construct Measurement and Validation Procedures in MIS and Behavioural Research: Integrating New and Existing Techniques. *MIS Quarterly*, 35 (2), 293-334.
- Mahlangu, E. N., & Makhitha, K. M. (2019). The impact of demographic factors on supermarket shopping motivations in South Africa. *Journal of Business and Retail Management Research*, 13 (3), 11-25.
- Matsunaga, M. (2010). How to Factor-Analyze Your Data Right: Do's, Don'ts, and How-To's. *International Journal of Psychological Research*, 3 (1), 97-110.
- Moutinho, L. A., Davies, F. M., Goode, M. M., & Ogbonna, E. (2001). Critical factors in consumer supermarket shopping behaviour: A neural network approach. *Journal of Consumer Behaviour: An International Research Review*, 1(1), 35-49.
- Neven, D., Reardon, T., Chege, J., & Wang, H. (2006). Supermarkets and consumers in Africa: the case of Nairobi, Kenya. *Journal of International Food & Agribusiness Marketing*, 18 (1-2), 103-123.
- Nguyen, D. T. N. (2020). Key operational factors for customer retention at supermarkets in Vietnam. *The Proceedings of Sixth International Conference on Finance and Economics*, 112-140.
- Nie, C., & Wang, T. (2021). How global brands incorporate local cultural elements to improve brand evaluations: A perspective on cultural mixing. *International Marketing Review*, 38 (1), 163-183.
- Noyan, F., & Şimşek, G. G. (2014). The antecedents of customer loyalty. *Procedia-Social and Behavioral Sciences*, 109, 1220-1224.
- Nyadzayo, M. W., & Khajehzadeh, S. (2016). The antecedents of customer loyalty: A moderated mediation model of customer relationship management quality and brand image. *Journal of Retailing and Consumer Services*, 30, 262-270.
- Oghojafor, B. E. A., Ladipo, P. K. A., & Nwagwu, K. O. (2012). Outlet attributes as determinants of preference of women between a supermarket and a traditional open market. *American Journal of Business and Management*, 1 (4), 230-240.
- Oliver, R. L. (1999). Whence Consumer Loyalty? *Journal of Marketing*, 63, 33-44.
- Orel, F. D., & Kara, A. (2014). Supermarket self-checkout service quality, customer satisfaction, and loyalty: Empirical evidence from an emerging market. *Journal of Retailing and Consumer Services*, 21 (2), 118-129.

- Rai, A. K., & Srivastava, M. (2012). Customer Loyalty Attributes: A Perspective. *NMIMS Management Review*, 22, 49-76.
- Raykov, T. (1997). Estimation of composite reliability for congeneric measures. *Applied Psychological Measurement*, 21 (2), 173-184.
- Reardon, T., Timmer, C. P., Barrett, C. B., & Berdegué, J. (2003). The rise of supermarkets in Africa, Asia, and Latin America. *American Journal of Agricultural Economics*, 85 (5), 1140-1146.
- Reichheld, F. F., Markey Jr, R. G., & Hopton, C. (2000). The loyalty effect- the relationship between loyalty and profits. *European Business Journal*, 12 (3), 134-139.
- Rishi, B., & Singh, H. (2012). Determinants of supermarket shopping behaviour in an emerging market. *Journal of Business and Retail Management Research*, 7 (1), 27-38.
- Russell-Bennett, R., McColl-Kennedy, J. R., & Coote, L.V. (2007). Involvement, satisfaction and brand loyalty in a small business services setting. *Journal of Business Research*, 60 (12), 1253-1260.
- Schreiber, J. B., Nora, A., Stage, F. K., Barlow, E. A., & King, J. (2006). Reporting Structural Equation Modeling and Confirmatory Factor Analysis Results: A Review. *The Journal of Educational Research*, 99 (6), 323-338.
- Seng, W. M. (2019). Design Science Approach to Build a Customer Satisfaction Theoretical Framework to Evaluate E-Government Services. *Electronic Journal of Information Systems Evaluation*, 22 (1), 54-64.
- Singh, J., & Sirdeshmukh, D. (2000). Agency and Trust Mechanisms in Consumer Satisfaction and Loyalty Judgements. *Journal of the Academy of Marketing Science*, 28, 150-167.
- Slack, N., Singh, G., & Sharma, S. (2020). Impact of perceived value on the satisfaction of supermarket customers: developing country perspective. *International Journal of Retail & Distribution Management*, 48 (11), 1235-1254.
- Terblanche, N. S. (2018). Revisiting the supermarket in-store customer shopping experience. *Journal of Retailing and Consumer Services*, 40, 48-59.
- Thakur, R., & Workman, L. (2016). Customer portfolio management (CPM) for improved customer relationship management (CRM): Are your customers platinum, gold, silver, or bronze? *Journal of Business Research*, 69 (10), 4095-4102.
- Theodoridis, P. K., & Chatzipanagiotou, K. C. (2009). Store image attributes and customer satisfaction across different customer profiles within the

- supermarket sector in Greece. *European Journal of Marketing*, 43 (5/6), 708-734.
- Thomas, A., & Garland, R. (1993). Supermarket shopping lists: their effect on consumer expenditure. *International Journal of Retail & Distribution Management*, 21 (2), 8-14.
- Watson, G. F., Beck, J. T., Henderson, C. M., & Palmatier, R. W. (2015). Building, measuring, and profiting from customer loyalty. *Journal of the Academy of Marketing Science*, 43 (6), 790-825.
- Westbrook, R. A., & Black, W. C. (1985). A motivation-based shopper typology. *Journal of Retailing*, 61 (1), 78-103.
- Xhema, J., Metin, H., & Groumpos, P. (2018). Switching Costs, Corporate Image and Product Quality effect on Customer Loyalty: Kosovo Retail Market. *IFAC PapersOnLine*, 51 (30), 287-292.
- Yi, Y., & Jeon, H. (2003). Effects of Loyalty Programs on Value Perception, Program Loyalty, and Brand Loyalty. *Journal of the Academy of Marketing Science*, 31 (3), 229-240.