



# UNIVERSITY OF RUHUNA

## Faculty of Engineering

End-Semester 4 Examination in Engineering: December 2015

Module Number: ME 4302

Module Name: Design of Machine Elements

[Three Hours]

[Answer all questions, each question carries 10 marks]

- 
- Q1. Internal stresses in machine elements are generated due to various loads acting on them.
- a) "Dead load" occurs due to self weight of a machine component. Briefly explain three other types of loads considered in design of machine components. [ 3 Marks]
- b) Figure Q1 shows a pile driving operation. The hammer is raised and allowed to fall in order to hit the pile so that the pile penetrates into soil.
- i. With the aid of a labeled sketch, identify the forces acting on the pile when it is driven into soil.
- ii. What are the failure modes of the pile when it undergoes the forces that you mentioned in (i) above?
- iii. What is the purpose of having a "cushion" shown in the Figure Q1?
- iv. Usually, when the pile meets a hard rock while penetrating in to the soil; the pile driving operation will be stopped. What could happen if we forcefully try to drive the pile beyond this point?
- v. The pile may be of reinforced concrete, wood or steel. Briefly explain the precautions to be taken when driving the pile for each material type. [5 Marks]
- c) Guide-way holds the pile upright and also it guides the falling hammer. What factors should be considered when designing the guide-way of the pile driving machine? [2 Marks]
- Q2. a) Considering the torque - speed characteristics of IC engines, briefly explain why automobiles are required a friction clutch, but not a positive clutch. [2.5 Marks]
- b) State five design considerations in designing a friction clutch [2.5 Marks]

- c) i. With usual notation, prove that the maximum torque  $T$  transmitted by a uniformly worn, single plate friction clutch is given by  $T = W (r_1 + r_2)/2$ .
- ii. Explain why certain machinery need multi-plate clutches.
- iii. A friction clutch having four friction pairs has to transmit 25 kW at 1500 rpm. The inner radius of the contact surface is 125 mm. The maximum pressure between the friction surfaces is limited to 0.1 N/mm<sup>2</sup> and the coefficient of friction is 0.3. Assuming uniform wear condition, find the outer radius of the friction surface.

[5 Marks]

- Q3. a) Explain the phenomenon "*Endurance or Fatigue Limit*" of a material with the aid of a suitable graph.

[2 Marks]

- b) The bending moment of a shaft varies from -150 Nm to 300 Nm. The endurance limit ( $\sigma_e$ ) of the shaft material is 260 MPa, ultimate tensile strength ( $\sigma_u$ ) is 700 MPa. Assuming the factor of safety ( $FS$ ) as 2, calculate the diameter of the shaft. Use Goodman's failure stress line given by  $1/FS = \sigma_m/\sigma_u + \sigma_v/\sigma_e$ , where  $\sigma_m$  and  $\sigma_v$  are mean stress and variable stress, respectively. With usual notation, bending stress ( $\sigma$ ) induced in a shaft due to bending moment ( $M$ ) is given by  $\sigma = My/I$ , where  $I = \pi d^4/64$  and  $y = d/2$ .

[3 Marks]

- c) With the aid of a sketch, explain how the reduction of diameter at a shoulder of a shaft affects its fatigue life. Modify the Goodman equation to include effects of stress concentration factor, size factor and surface finish factor.

[3 Marks]

- d) A shoulder cut on the shaft you designed in above part (b) results in a stress concentration factor of 1.5. Taking a size factor of 0.85 and a surface finish factor of 0.9, re-calculate the shaft diameter for the same loading conditions.

[2 Marks]

- Q4. a) Explain the requirement of couplings when connecting two shafts. Why is it essential to have flexible couplings for certain applications?

[3 Marks]

- b) A flange coupling has to be designed for a steel shaft transmitting 40 kW of power at 350 rpm. The allowable shear stress of the shaft is 40 MPa and the shear stress in the bolts should not exceed 30 MPa. Assume that the same material is used for shaft and key, and the crushing stress value is twice the value of its shear stress.

Referring to Figure Q4 and Table Q4;

- i. Find the diameter of the bolts.
- ii. If the width of the square key is 18 mm, check the strength of the key.

[4 Marks]

- c) "In practice, it is possible to safely use the same number of bolts having smaller diameter than what you found in b) i. above; as long as all bolts are properly tightened" - Explain the validity of this statement.

[3 Marks]

- Q5. a) Compare the advantages of using flat belt drives over chain drives.

[2 Marks]

- b) The tension of a belt caused by centrifugal force should be taken into account when the belt runs faster than 10 m/s. Show that the centrifugal tension  $T_c$  of a belt drive  $T_c = mv^2$ , where  $m$  is the mass of unit length and  $v$  is the belt speed.

[2 Marks]

- c) A flat belt drive has been connected to a 15 kW motor running at 1750 rpm. The density of the belt material is  $1500 \text{ kg/m}^3$ , maximum allowable stress is 4 MPa, friction coefficient  $\mu$  is 0.4, motor pulley diameter is 210 mm and angle of lap is  $160^\circ$ . Determine the cross sectional area of the belt. The relationship between belt tensions is given by  $T_1/T_2 = e^{\mu\theta}$  with usual notations.

[4 Marks]

- d) If the belt discussed in section (b) above is replaced by a 20% more heavier belt, what would be the effect on power transmitted?

[2 Marks]

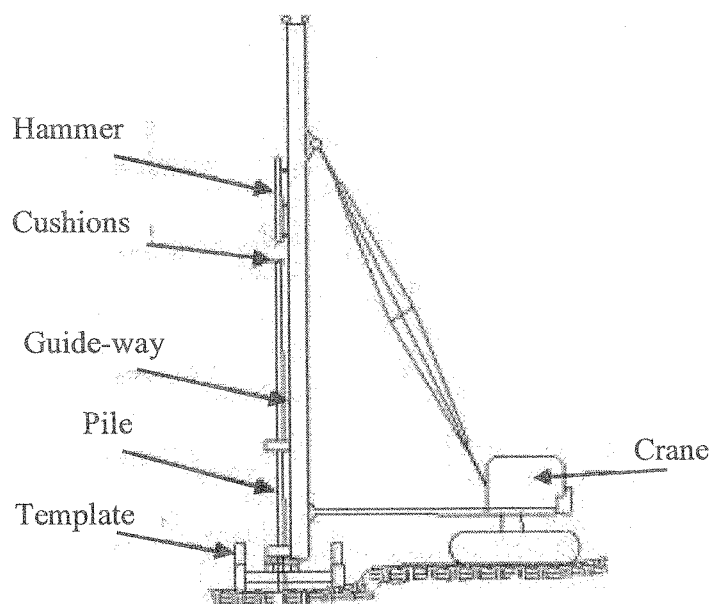

Figure Q1

