



UNIVERSITY OF RUHUNA

Faculty of Engineering

End-Semester 4 Examination in Engineering: November 2022

Module Number: ME4305

Module Name: Mechanics of Machines

[Three Hours]

[Answer all questions, each question carries 12 marks]

This paper contains 5 questions on 7 pages.

Clearly state all the assumptions that you may make.

To get full marks, make sure that you have answered with correct SI units and standard notations. Take $g = 9.8 \text{ m/s}^2$.

- Q1.** a) A slider-crank mechanism is shown in Figure Q1(a).
- Represent each link using vectors and draw the vector diagram. Assume, link lengths and angles using variables by clearly showing those in the diagram.
 - Write down loop closure equation using the above vectors.
 - Derive an expression for the piston's displacement and velocity using the lengths of links, θ_2 and taking the angular velocity of the link 2 is ω in clock-wise and it is a constant.
- [4.0 Marks]
- b) Refer the skeleton diagram shown in Figure Q1(b). Assume that the piston moves horizontally and the displacement of the piston (x) is measured from the left-most position of the piston at which OB gets its maximum length. Determine,
- expressions for the piston's displacement, velocity and the acceleration,
 - the primary and secondary forces.
- [4.0 Marks]
- c) A compressor shown in Figure Q1(c) has three inline pistons each having mass of 0.6 kg with a crank radius of 45 mm and ratio, $n=L/R=3$. Assume that the cranks are equally spaced in angle and position. Given that $x_1 = 50 \text{ mm}$, $x_2 = 100 \text{ mm}$, $x_3 = 150 \text{ mm}$ and $d = 200 \text{ mm}$. Determine,
- the primary force,
 - the secondary force,
 - the turning moment about the reference plane X when it revolves at 360 rpm.
- [4.0 Marks]
- Q2.** a) Briefly explain why balancing is important for reciprocating machines stating 4 reasons.
- [4.0 Marks]

- b) i) State the conditions that should be satisfied to achieve complete mechanical system balance.
- ii) A rigid rotor shown in Figure Q2(b) carries three thin discs A, B, and C with diameters d_1 , d_2 , and d_3 and masses m_1 , m_2 , and m_3 respectively. The discs are mounted on an L long shaft. Take $OA=L_1$, $OB=L_2$, $OC=L_3$. All are in SI units. Derive mathematical expressions to be satisfied to achieve complete mechanical system balance stated in above b) i).

[4.0 Marks]

- c) Given that the rigid rotor shown in Figure Q2(b) has following dimensions, $OA = 50$ mm, $OB = 600$ mm, $OC = 850$ mm and the shaft length is 1 m, and properties as given in Table Q2(b). Further, it is given that the rotor is suspended from a bearing at O with the other end unrestrained. Calculate,
- i) the corrective balance needed to ensure that end Z does not move, assuming that it can only be balanced on disc C.
- ii) The magnitude of the force resulting at O when the shaft revolves at 720 rpm.

[4.0 Marks]

- Q3. a) Briefly describe the following terms relating to spur gear using an appropriate diagram.
- i) Addendum.
- ii) Dedendum.
- iii) Clearance.
- iv) Pressure angle.

[2.0 Marks]

- b) What is meant by the interference in spur gears? Briefly explain a method to avoid it.

[1.5 Marks]

- c) The compound gear train given in Figure Q3(c) is used to lift a 50 kg load at a constant velocity of 0.5 m/s using a motor attached to the input gear A. The diameter of the output pulley is 10 cm. Assume there are no losses between the gears and pulleys. Answer the followings,
- i) Find the torque required at the motor to support the weight.
- ii) Determine the rotating direction of the motor to lift the load.
- iii) Calculate the required rotational speed of the motor to lift the load at the given linear speed.

[5.0 Marks]

- d) Describe three possible power transmission options of epicyclic gear train.

[1.5 Marks]

- e) List, two practical applications and two advantages of epicyclic gear trains over ordinary and compound gear trains.

[2.0 Marks]

- Q4. a) With the help of neat sketches, explain the types of cams and followers. [3.0 Marks]
- b) A shoe manufacture requires to set out a profile of a cam having an oscillating follower movement for his stamping machine, as described below.
- Lift of the follower is of 40 mm during the first 90° of cam rotation.
 - Dwell for the next 60° .
 - During the next 90° of cam rotation, the follower returns to its original position.
 - Dwell during the remaining 120°

Take the radius of the base circle of the cam as 30 mm.

- i) Design the profile of the cam to maintain a constant velocity for the follower during rising and falling.
- ii) Calculate the rotational speed of the cam if the linear velocity of the follower is 15 mm/s during both rise and fall.

[5.0 Marks]

- c) The Torque–Crank Angle diagram for a crank piston engine is given in Figure Q4(c). The work done during each step is indicated in the diagram, and the crank shaft needs to maintain the speed within the range 540 - 550 rev/ min.

- i) Determine the moment of inertia of a suitable flywheel for the given application in order to maintain the required speed range.
- ii) Find the mass of the flywheel with a radius of gyration of 0.5 m.

[4.0 Marks]

- Q5. a) Explain the difference between dead weight type governors and spring-loaded type governors.

[2.0 Marks]

- b) Hartung governor is one of spring-loaded type governors. List two other governors in the category of spring-loaded type governors.

[2.0 Marks]

- c) A simple (pinned) arm Watt governor given in Figure Q5(c) has following design and current operating parameters. Assume, there is no tension in lower arms because, the sleeve is frictionless and weight of arms are negligible.

- Mass of the ball = 2 kg
- Radial distance of balls from the axis of the spindle = 0.1 m
- Angular velocity of the balls and arms about the spindle axis = 5 rad/s
- Gravitational acceleration = 9.81 m/s^2

Calculate,

- i) the centrifugal force acting on a ball.
- ii) the vertical distance between the centre of the ball and the point O.
- iii) the θ value.
- iv) the tension of the upper arm.

[4.0 Marks]

- d) A Hartung governor is installed as its rotation axis is vertical. The arms connected to spring ball and the arms connected to moving sleeve are connected with each other 90-degree angles as shown in Figure Q5(d). Draw the free body diagram for two connected arms (arm connected to spring ball and the arm connected to moving sleeve) at the mean position and mark all the forces contributing to moment around the connection between two arms. Mark all the required distance values and other parameters contributing to moment around the connection, label and explain them.

[4.0 Marks]

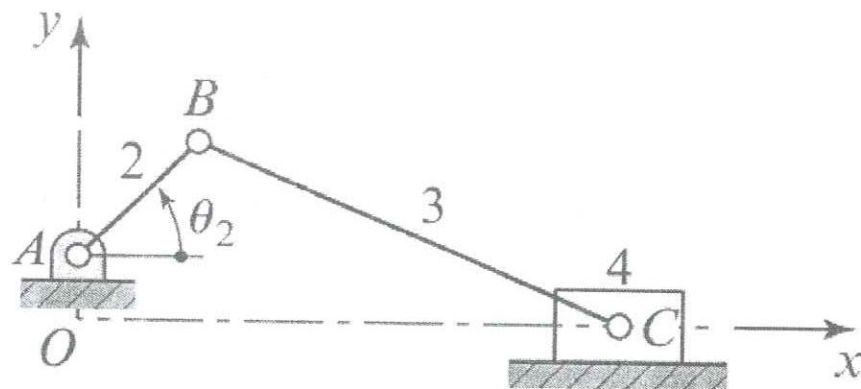

Figure Q1(a): Slider-crank mechanism

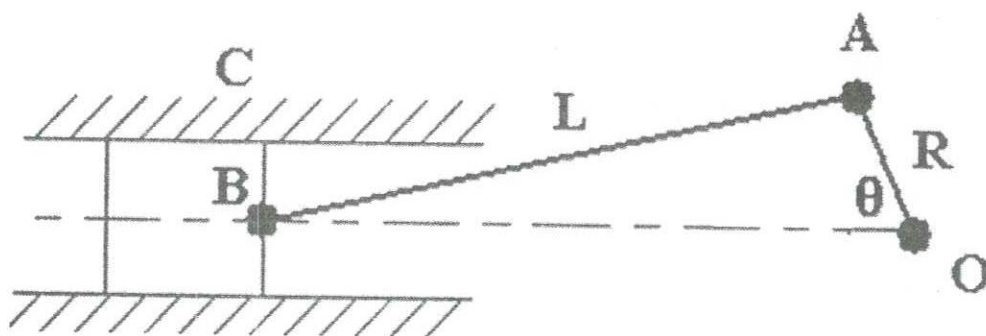

Figure Q1(b): Skeleton diagram

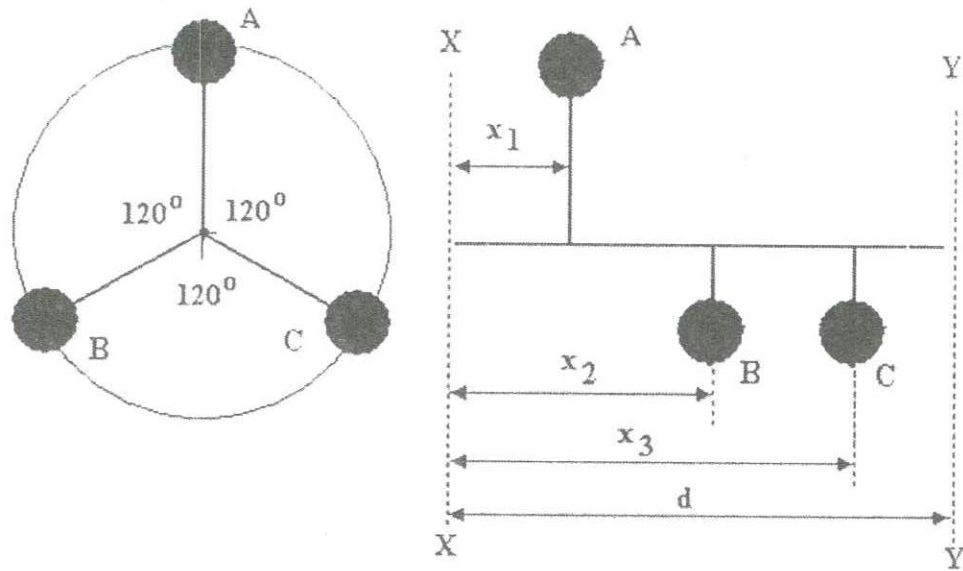

Figure Q1(c)

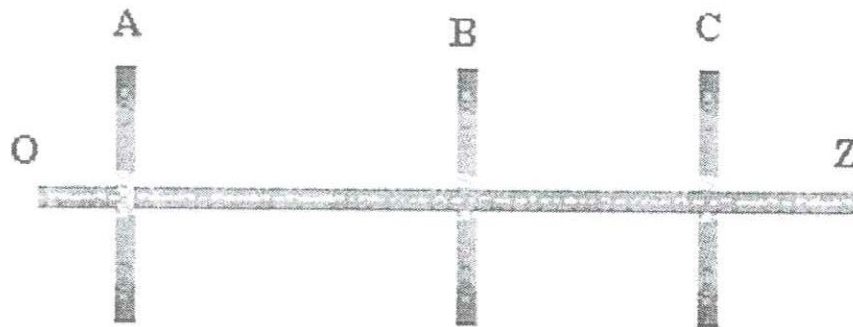

Figure Q2(b): A rigid rotor

Disc	Diameter (mm)	Mass (kg)	Angle (θ , deg)
A	800	50	0
B	600	42	120
C	900	36	300

Table Q2(b): Rigid rotor data

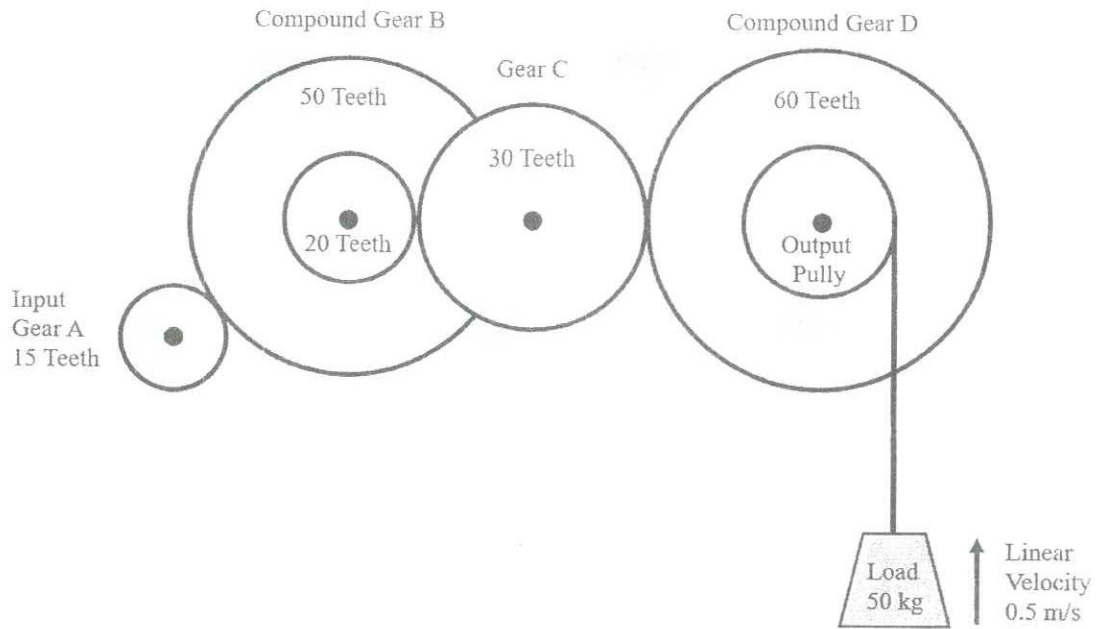

Figure Q3(c): The arrangement of the compound gear train

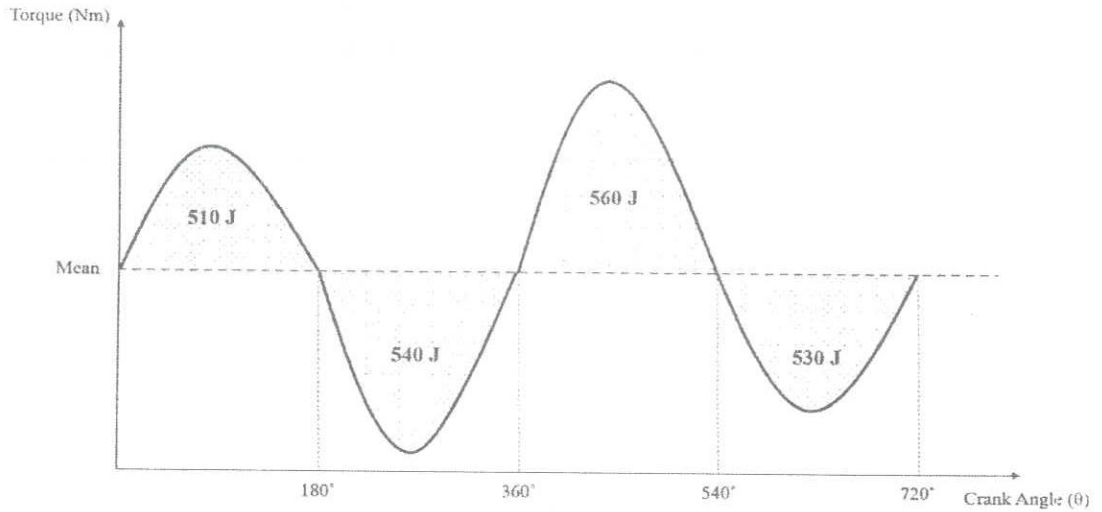

Figure Q4(c): Torque-crank angle diagram

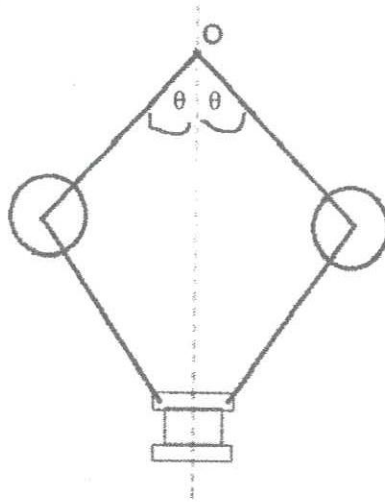

Figure Q5(c): Simple (pinned) arm Watt governor

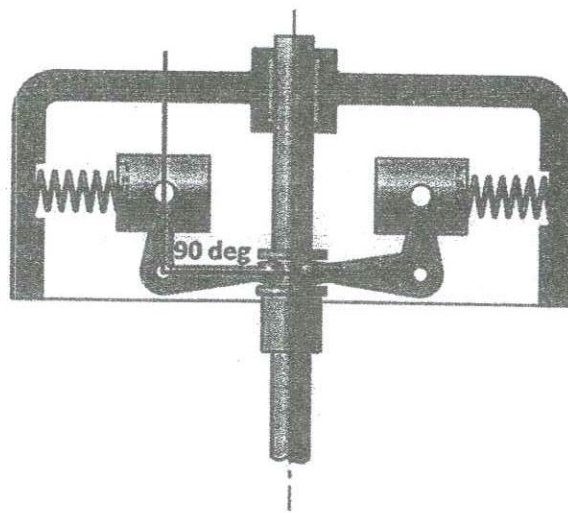

Figure Q5(d): Hartung governor