



UNIVERSITY OF RUHUNA

Faculty of Engineering

End-Semester 2 Examination in Engineering: December 2016

Module Number: ME2201

Module Name: Engineering Mechanics

[Three Hours]

[Answer **all questions**; each question carries **ten marks**; provide neat sketches where necessary; make reasonable assumptions and state them clearly]

-
- Q1 a) Clearly mention the classification of mechanics with suitable examples [2.0 Marks]
- b) What are the characteristics of a force moment and provide two examples [2.0 Marks]
- c) To close a gate valve it is necessary to apply 60 N force each of the opposite sides of a hand wheel of 50cm in diameter. Due to an accident the wheel is broken and the valve must be closed using a thrust bar that is inserted through a slot in the valve system and by exerting a force at distance 75cm from the center of the valve. Determine the force required and draw a free-body diagram of the bar. [3.0 Marks]
- d) A pulley of 40cm in diameter and supporting a load of 200N is mounted at B on a horizontal beam as shown in Figure Q1 (d). The beam is supported by a hinge at A and rollers at C. Neglecting the weight of the beam, determine the reactions at A and C. [3.0 Marks]
- Q2 a) What is meant by a free body diagram? [1.0 Mark]
- b) Name four mechanisms, that can be used to design a machine [2.0 Marks]
- c) What is meant by degrees of freedom (DOF) of a rigid body system? [1.0 Mark]
- d) Find the DOF of given rigid body system shown in figure Q2(d) [2.0 Marks]
- e) A small scale wall decoration cards manufacturer needs a manually operated punching machine to cut various shapes of blocks on papers. The Manufacturer has ordered all the required blocks, however he does not have a strong punching mechanism. Propose a suitable punching machine by using your engineering mechanics knowledge [4.0 Marks]
- Q3 a) Obtain the governing differential equations of the system shown in figure Q3(a). Specify the notations that you use. [4.0 Marks]

- b) In the gear system given in Figure Q3 (b), gear A revolves at 90revs/min. Number of gear teeth on gear A and B are 30 and 20 respectively. It is required to obtain rotational speed of 50revs/min for a given application. If you are asked to order a gear wheel that can be meshed with gear B, what is your main consideration before placing the order?

[2.0 Marks]

c)

	Gear A	Gear B
Moment of Inertia	J_A	J_B
Rotational Friction	B_A	B_B
Angle	ϕ_A (Positive clockwise)	ϕ_B (Positive counter clockwise)

Considering mathematical model of the above gear system, obtain the set of differential equations that describe the system. The torque τ_a acts in the direction of ϕ_A and T_L is the load torque applied by the load connected to the gear wheel B

[4.0 Marks]

- Q4 a. Briefly discuss the difference between kinematic and Kinematics of particles.

[1.0 Mark]

- b. A projectile is ejected into an experimental fluid at time $t=0$. The initial speed is v_0 and the angle to the horizontal is θ as shown in the figure Q4 (b). The drag on the projectile results in an acceleration term $a_D = -k.v$, Where k is a constant and the v is the velocity of the projectile. Determine the **x** and **y** components of both the **velocity** and **acceleration** as functions of time. Include the effects of gravitational acceleration.

[5.0 Marks]

- c. For the derived expressions of motion in Q4 b) write a Matlab code to simulate the projectile motion in x-y plane and to plot the velocity variation of the particle.

[4.0 Marks]

- Q5 a. In plane kinematics of particle motion we use n-t (normal- tangential) coordinates to describe the particle motion. Using suitable sketches and notations derive expressions for the accelerations in the n and t direction. Express the governing equations using polar coordinates.

[3.0 Marks]

- b. State the Newton second laws of motion and write down the corresponding governing equations in the n-t coordinates system.

[2.0 Marks]

- c. A small vehicle enters the top A of the circular path with a horizontal velocity v_0 and gathers speed as it moves down the path as shown in figure Q5 (c). Determine an expression for the angle β which locates the point where the vehicle leaves the path and becomes a projectile.

[5.0 Marks]

- Q6 a. Define the term **rigid body** by stating the rigid body assumptions and Briefly

discuss the types of rigid body plane motions.

[1.0 Marks]

- b. Write down the relative accelerations and velocities in a non-rotating frame of reference for planar rigid body motion.

[1.0 Mark]

- c. Crank CB oscillates about C through a limited arc, causing crank OA to oscillate about O as shown in Figure Q6 (c). When the linkage passes the position shown with CB horizontal and OA vertical, the angular velocity of CB is 2 rad/s in the counterclockwise direction. For this instance,

- I. Determine the angular velocities of OA and AB
- II. Determine the angular accelerations of OA and AB

[5.0 Marks]

- d. Derive the equations for relative acceleration and velocity of rigid body motion in a rotating frame using suitable sketches and notations. Briefly explain with the derived results the meaning of coriolis acceleration.

[3.0 Marks]

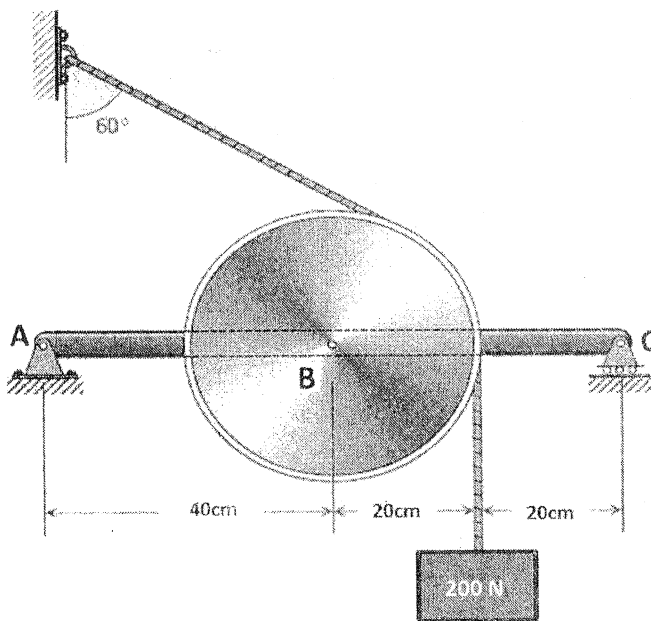

Figure Q1(d)

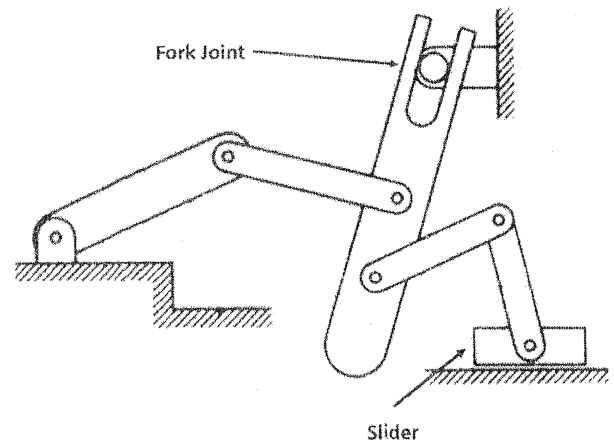

Figure Q2(d)

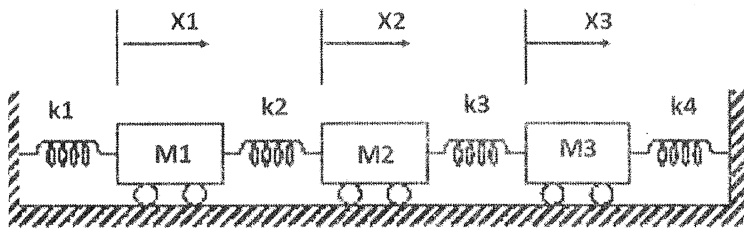

Figure Q3(a)

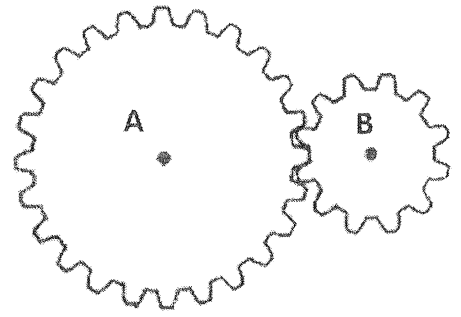

Figure Q3(b)

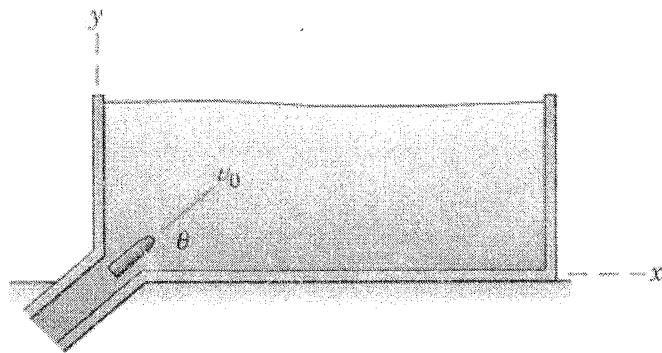

Figure Q4(b)

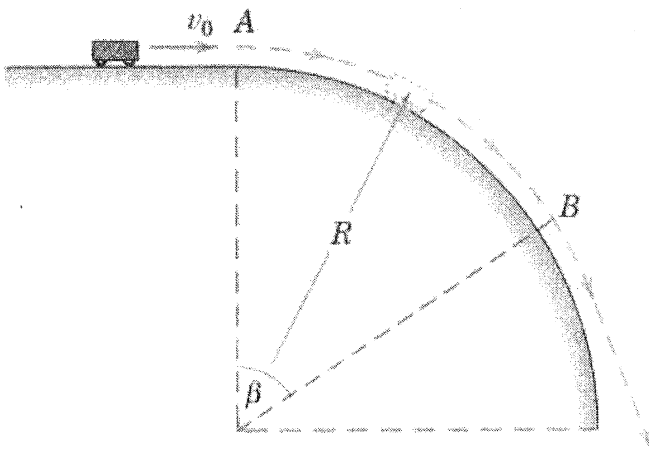

Figure Q5(c)

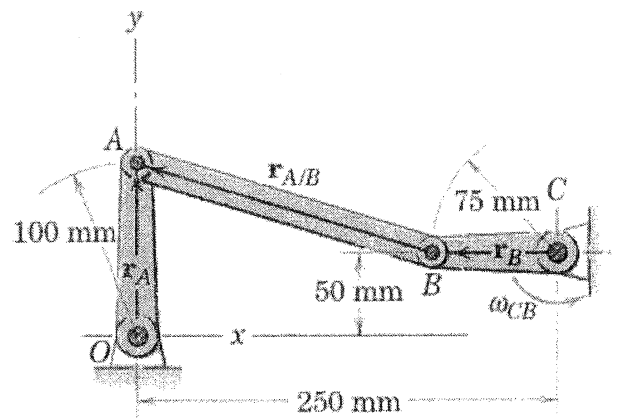

Figure Q6(c)