

Part II only

Index Number:



UNIVERSITY OF RUHUNA
FACULTY OF FISHERIES AND MARINE SCIENCES &
TECHNOLOGY

Academic Year 2023/2024

Bachelor of Science Honours in Fisheries and Marine Sciences Degree/
Bachelor of Science Honours in Marine and Freshwater Sciences Degree

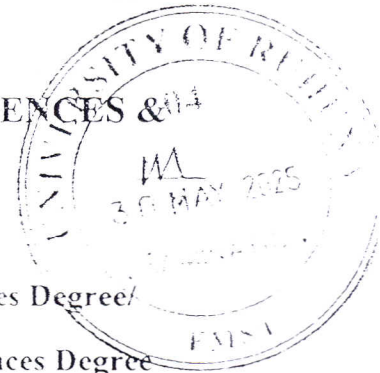

Level III Semester II Examination – April/May 2025

CHM 3211: Radiochemistry

Time: 01 hour and 15 minutes

Instructions:

- Answer all questions in the paper itself and submit.
- In each of the questions 1-15 in part I, pick one of the alternatives from (a), (b), (c), (d), and (e) which is correct or most appropriate, and underline your selection.
- Answer each question in part II in the given spaces. (*Note that the answers written in extra papers will not be considered)

Part II- (70 marks)

I) Answer all parts (35 marks)

a) I) Below is the decay series for a uranium-238 nuclide, showing all the steps of decay that occur before it finally reaches a stable state. Fill in the blanks with either the type of decay that occurs to get from one step to another or with the name of the isotope produced at a certain step.

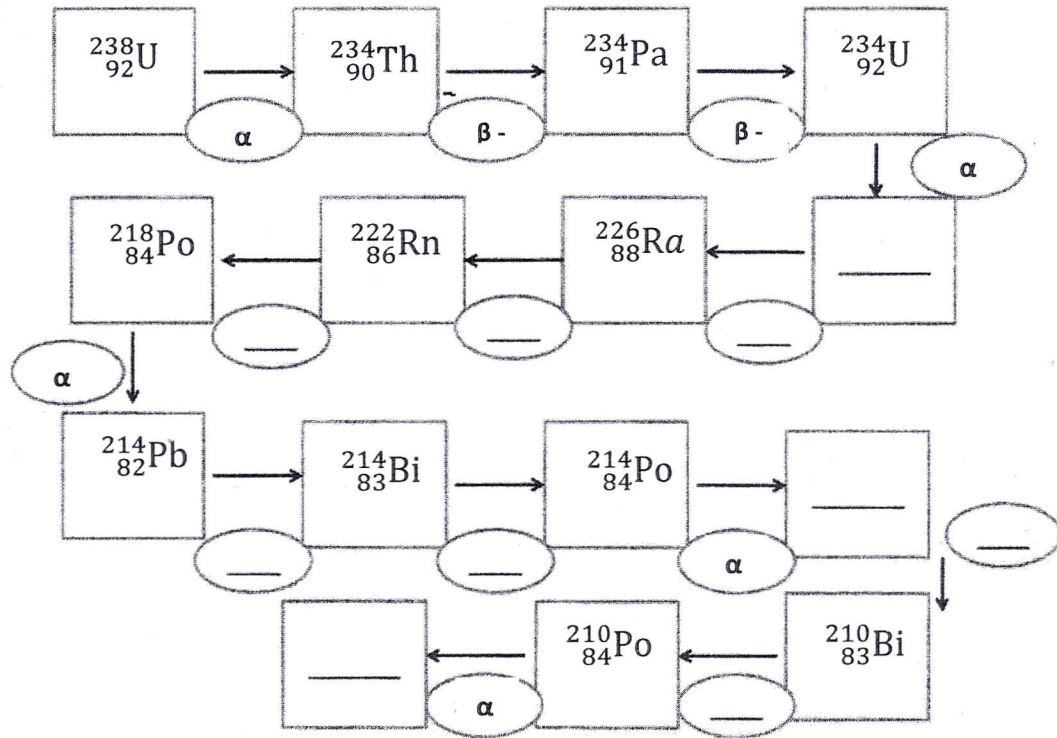

(15 marks)

II) Sketch the relevant decay schemes for following nuclear reactions.

a) ${}_{92}^{238}\text{U}$ converting into ${}_{90}^{234}\text{Th}$

b) Handling nuclear waste should be done in a strategic manner.

I. What are the major types of nuclear waste produced in the world? Give one example for each type.

.....
.....
.....
.....
.....
.....
.....
.....
.....
.....

(04 marks)

II. What are the major ways used to dispose of nuclear waste?

.....
.....
.....
.....
.....
.....
.....
.....
.....
.....

(03 marks)

III. Write a short note on the use of the multinational repository for discarding nuclear waste.

.....
.....
.....
.....
.....
.....
.....
.....
.....
.....
.....
.....
.....
.....
.....
.....
.....
.....
.....
.....
.....

(05 marks)

18 marks)

@@@@@@@@@@@@@@@@@@@@

Periodic Table of the Elements

1 IA 1A	2 IIA 2A											18 VIIIA 8A					
3 IIIB 3B	4 IVB 4B	5 VB 5B	6 VIB 6B	7 VIIB 7B	8 VIII 8	9 VIII 9	10 VIII 10	11 IB 1B	12 IIB 2B	13 IIIA 3A	14 IVA 4A	15 VA 5A	16 VIA 6A	17 VIIA 7A	18 VIIIA 8A		
1 H Hydrogen 1.008	2 He Helium 4.003	3 Li Lithium 6.941	4 Be Beryllium 9.012	5 B Boron 10.811	6 C Carbon 12.011	7 N Nitrogen 14.007	8 O Oxygen 15.999	9 F Fluorine 18.998	10 Ne Neon 20.180	11 Na Sodium 22.990	12 Mg Magnesium 24.305	13 Al Aluminum 26.982	14 Si Silicon 28.086	15 P Phosphorus 30.974	16 S Sulfur 32.066	17 Cl Chlorine 35.453	18 Ar Argon 39.948
19 K Potassium 39.098	20 Ca Calcium 40.078	21 Sc Scandium 44.956	22 Ti Titanium 47.88	23 V Vanadium 50.942	24 Cr Chromium 51.986	25 Mn Manganese 54.938	26 Fe Iron 55.833	27 Co Cobalt 58.933	28 Ni Nickel 58.693	29 Cu Copper 63.546	30 Zn Zinc 65.39	31 Ga Gallium 69.723	32 Ge Germanium 72.61	33 As Arsenic 74.922	34 Se Selenium 78.96	35 Br Bromine 79.904	36 Kr Krypton 83.80
37 Rb Rubidium 84.468	38 Sr Strontium 87.62	39 Y Yttrium 88.906	40 Zr Zirconium 91.224	41 Nb Niobium 92.906	42 Mo Molybdenum 95.94	43 Tc Technetium 98.907	44 Ru Ruthenium 101.07	45 Rh Rhodium 102.906	46 Pd Palladium 106.42	47 Ag Silver 107.868	48 Cd Cadmium 112.411	49 In Indium 114.818	50 Sn Tin 118.71	51 Sb Antimony 121.760	52 Te Tellurium 127.6	53 I Iodine 126.904	54 Xe Xenon 131.29
55 Cs Cesium 132.905	56 Ba Barium 137.327	57-71 Lanthanide Series	72 Hf Hafnium 178.49	73 Ta Tantalum 180.948	74 W Tungsten 183.85	75 Re Rhenium 186.207	76 Os Osmium 190.23	77 Ir Iridium 192.22	78 Pt Platinum 195.08	79 Au Gold 196.967	80 Hg Mercury 200.59	81 Tl Thallium 204.383	82 Pb Lead 207.2	83 Bi Bismuth 208.980	84 Po Polonium [209]	85 At Astatine [210]	86 Rn Radon 222.018
87 Fr Francium 223.020	88 Ra Radium 226.025	89-103 Actinide Series	104 Rf Rutherfordium [261]	105 Db Dubnium [262]	106 Sg Seaborgium [266]	107 Bh Bohrium [264]	108 Hs Hassium [269]	109 Mt Meitnerium [268]	110 Ds Darmstadtium [269]	111 Rg Roentgenium [272]	112 Cn Copernicium [277]	113 Nh Nihonium [284]	114 Fl Flerovium [289]	115 Mc Moscovium [288]	116 Lv Livermorium [293]	117 Ts Tennessine [294]	118 Og Oganesson [294]

57 La Lanthanum 138.906	58 Ce Cerium 140.115	59 Pr Praseodymium 140.908	60 Nd Neodymium 144.24	61 Pm Promethium [144.913]	62 Sm Samarium 150.36	63 Eu Europium 151.966	64 Gd Gadolinium 157.25	65 Tb Terbium 158.925	66 Dy Dysprosium 162.50	67 Ho Holmium 164.930	68 Er Erbium 167.26	69 Tm Thulium 168.934	70 Yb Ytterbium 173.04	71 Lu Lutetium 174.967
89 Ac Actinium 227.028	90 Th Thorium 232.038	91 Pa Protactinium 231.036	92 U Uranium 238.029	93 Np Neptunium 237.048	94 Pu Plutonium 244.064	95 Am Americium 243.061	96 Cm Curium 247.070	97 Bk Berkelium 247.070	98 Cf Californium 251.080	99 Es Einsteinium [254]	100 Fm Fermium 257.095	101 Md Mendelevium 258.1	102 No Nobelium 259.101	103 Lr Lawrencium [262]

- Alkali Metal
- Alkali Earth
- Transition Metal
- Basic Metal
- Semimetal
- Nonmetal
- Halogen
- Noble Gas
- Lanthanide
- Actinide